

Panasonic

2.4GHz Cordless Answering System

Model No. **KX-TG2593B**

Pulse or-tone dialing capability

Operating Instructions



2 LINE

Caller ID Compatible

PLEASE READ BEFORE USE AND SAVE.

Charge the battery for about 8 hours before initial use.

Panasonic World Wide Web address: <http://www.panasonic.com>
for customers in the USA or Puerto Rico

Preparation

Cordless Telephone

Answering System

Useful Information

Before Initial Use

Please read **IMPORTANT SAFETY INSTRUCTIONS** on page 92 before use.
Read and understand all instructions.

Thank you for purchasing your new Panasonic cordless telephone.

Caller ID and Call Waiting Service, where available, are telephone company services. After subscribing to Caller ID, this phone will display a caller's name and phone number. Call Waiting Caller ID, which displays a second caller's name and phone number while the user is on another call, requires a subscription to both Caller ID and Call Waiting.

Attach your purchase receipt here.

For your future reference

Serial No. _____
(found on the bottom of the unit)

Date of purchase _____

Name and address of dealer _____

Accessories (included) For extra orders, call 1-800-332-5368.

- AC Adaptor (p. 10)
Order No. PQLV10Z

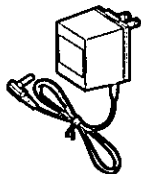

one

- 4-Wire Telephone
Line Cord with Green
Plugs (p. 11, 12)

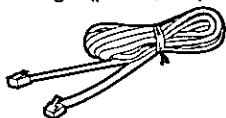

one

- 2-Wire Telephone Line
Cord with Transparent
Plugs (p. 12)



one

- Wall Mounting Adaptor (p. 80)
Order No. PQKL10038Y3



one

- Belt Clip (p. 82)
Order No. PQKE10127Z1

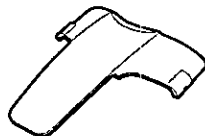

one

For Best Performance

Battery Charge

A rechargeable Ni-Cd battery powers the handset. Charge the battery for about **6 hours** before initial use (p. 13).



Base Unit Location/Noise

Calls are transmitted between the base unit and the handset using wireless radio waves. **For maximum distance and noise-free operation**, the recommended base unit location is:

Away from electrical appliances such as a TV, personal computer or another cordless phone.

In a **HIGH** and **CENTRAL** location with no obstructions such as walls.

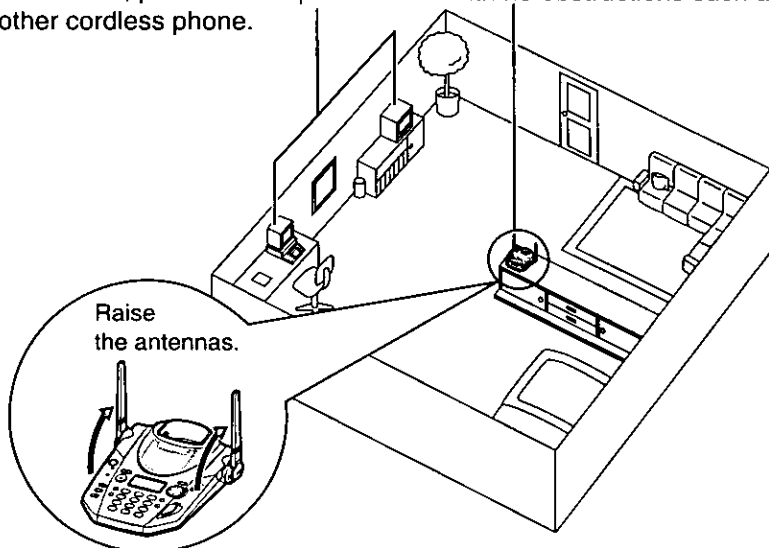

Note:

While using the handset:

- If you are near a microwave oven which is being used, noise may be heard from the receiver. Move away from the microwave oven and closer to the base unit.
- If more than one cordless phone is being used and your handset is near another cordless phone's base unit, noise may be heard. Move away from the other cordless phone's base unit and closer to your base unit.

Contents

Preparation

Location of Controls	6
Displays	9
Settings	10
Connecting the AC Adaptor	10
Connecting the Telephone Line Cord	11
Battery Charge	13
Selecting the Dialing Mode	15
Selecting the Line Mode	16
Programmable Functions	17
Setting the Auto Talk Feature	18
Selecting the Ringer Volume	19
Preparing the Answering System	21
Greeting Message	21
Programming Summary for the Answering System	23
Day and Time Adjustment	24
Selecting the Caller's Recording Time	26
Selecting the Number of Rings	27

Cordless Telephone

Making Calls	28
With the Handset	28
With the Base Unit (Digital Duplex Speakerphone)	31
Answering Calls	33
With the Handset	33
With the Base Unit (Digital Duplex Speakerphone)	33
Caller ID Service	34
Using the Caller List	36
Viewing the Caller List	36
Calling Back from the Caller List	37
Editing the Caller's Phone Number	38
Storing Caller List Information in the Directory	40
Erasing Caller List Information	41
One-Touch Dialer	43
Storing a Phone Number in the DIRECT Button	43
Dialing the Stored Number in the DIRECT Button	44
Using the Directory	45
Storing Names and Numbers in the Directory	45
Selecting Characters to Enter Names	47
Finding Items in the Directory	49
Dialing from the Directory	51
Editing an Item in the Directory	52

Erasing an Item from the Directory	53
Using the Other Line During a Conversation	54
While Someone Else is Using a Line (Simultaneous Base/Handset Calling)	54
While You are Using a Line	55
Conference Call	56
Intercom	57
Transferring a Call Using the Intercom	58
Special Features	59
Automatic Security Code Setting	59
How to Use the PAUSE Button (For Analog PBX Line/Long Distance Service Users)	59
For Call Waiting Service Users	60
Temporary Tone Dialing (For Rotary or Pulse Service Users)	60
FLASH Button	61
Line Selection	62
Incoming Call Tone	63

Answering System

Automatic Answering Operation	64
Setting the Unit to Answer Calls	64
Listening to Messages	66
From the Handset	68
Erasing Messages	69
Remote Operation from a Touch Tone Phone	70
Setting the Remote Code	71
Voice Menu	72
Direct Remote Operation	74
Remote Operation with the Handset	77

Useful Information

Wall Mounting	80
Using the Belt Clip	82
Using an Optional Headset	82
Battery Replacement	83
If the Following Appear...	84
Before Requesting Help	86
Adding Another Phone	91
Important Safety Instructions	92
FCC and Other Information	94

Location of Controls

Base unit

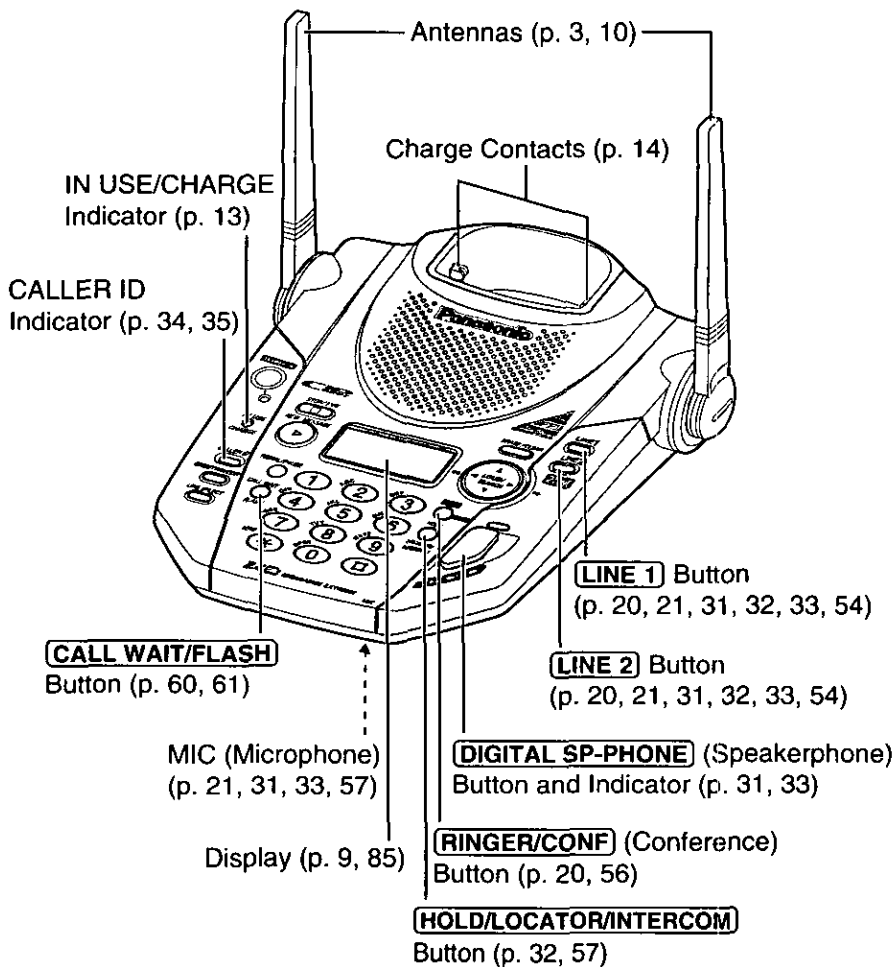

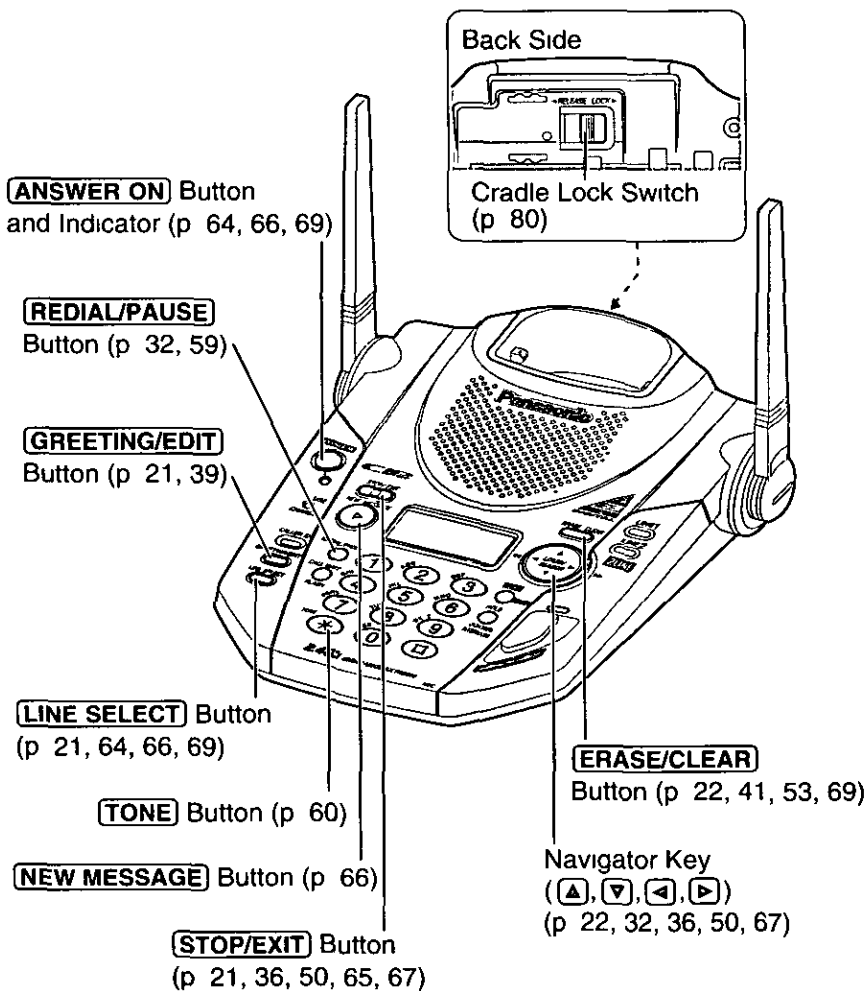

➔ Location of Controls

Handset

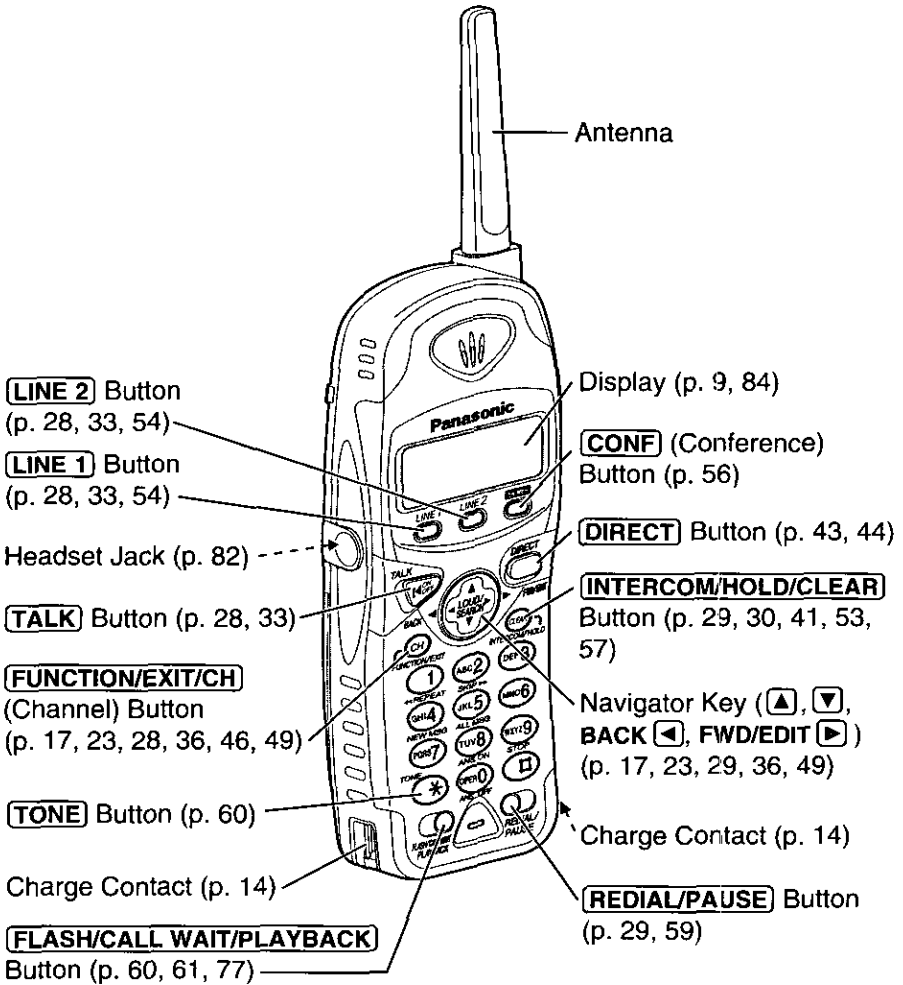

Displays

Handset

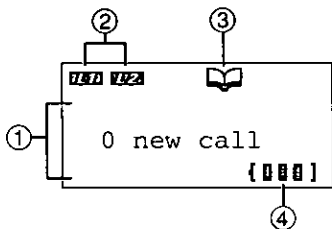

①The display shows the dialed number, call status, programming options and directory items etc. If you subscribe to a Caller ID service, caller information will be displayed (p. 34). The number of new calls will also be displayed.

②Indicate the line status (p. 30).

③The directory icon displays when storing or viewing the directory items (p. 46, 49).

④The battery icon indicates the battery strength (p. 13).

Standby mode:

While the handset is off the base unit, the display becomes blank after you finish using the handset (making/answering a call, viewing the Caller List or directory list etc.). The handset can receive calls. The battery life is conserved in this state. While the handset is on the base unit, the battery icon and the number of new Caller ID calls are displayed in the standby mode (p. 34).

Base unit

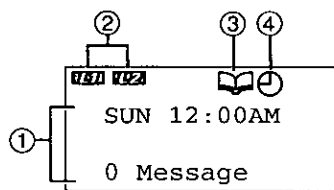

①The day and time and the number of incoming messages are displayed while the unit is not in use (**Standby mode**). The display shows the dialed number, call status, programming options and directory items etc.

If you subscribe to a Caller ID service, caller information will be displayed (p. 34). The number of new calls will also be displayed.

②The line icon(s) will be displayed when you select the line(s) to record the greeting messages, to turn the answering system on/off or to listen to messages. They will flash while the answering system is responding to a call or while messages on that line are being played (p. 64, 66).

③The directory icon displays when viewing the directory items (p. 50).

④The clock icon flashes with the day and time if the clock needs adjusting (p. 24).

Settings

Connecting the AC Adaptor

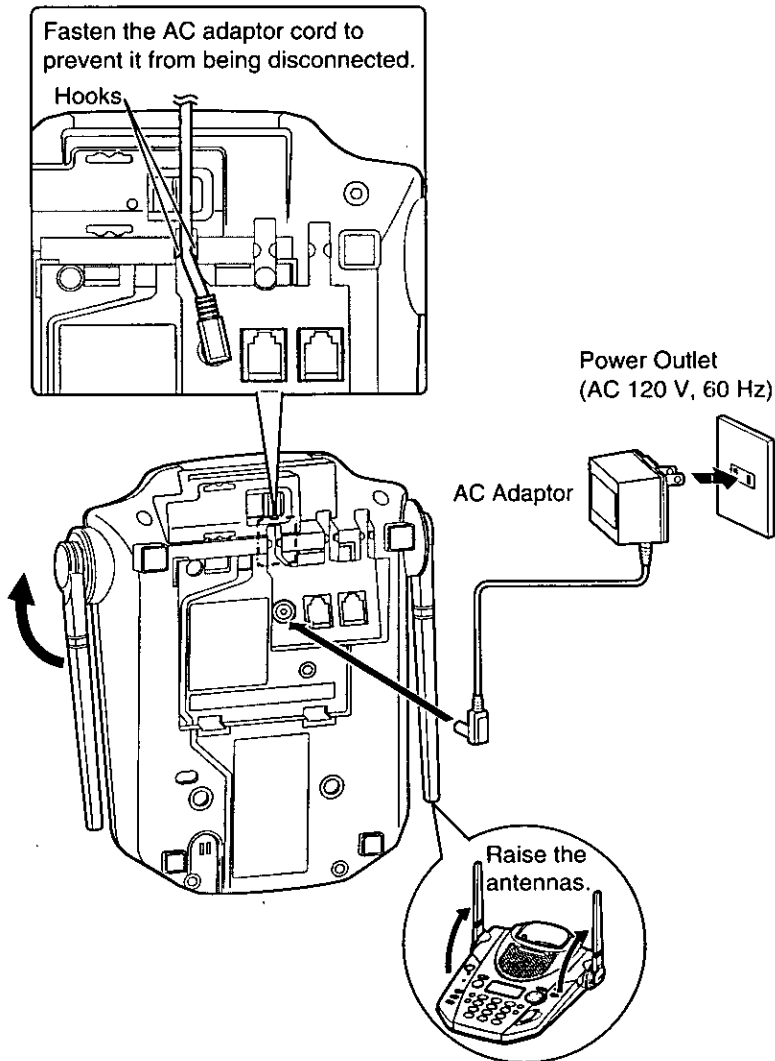

- USE ONLY WITH Panasonic AC ADAPTOR PQLV10 (Order No. PQLV10Z).
- The AC adaptor must remain connected at all times. (It is normal for the adaptor to feel warm during use.)
- To connect a standard telephone on the same line, see page 91.
- If your unit is connected to a PBX which does not support Caller ID services, you cannot access those services.



Connecting the Telephone Line Cord

Connect the telephone line cord(s) to the unit as follows

To connect a two-line telephone jack

Preparation

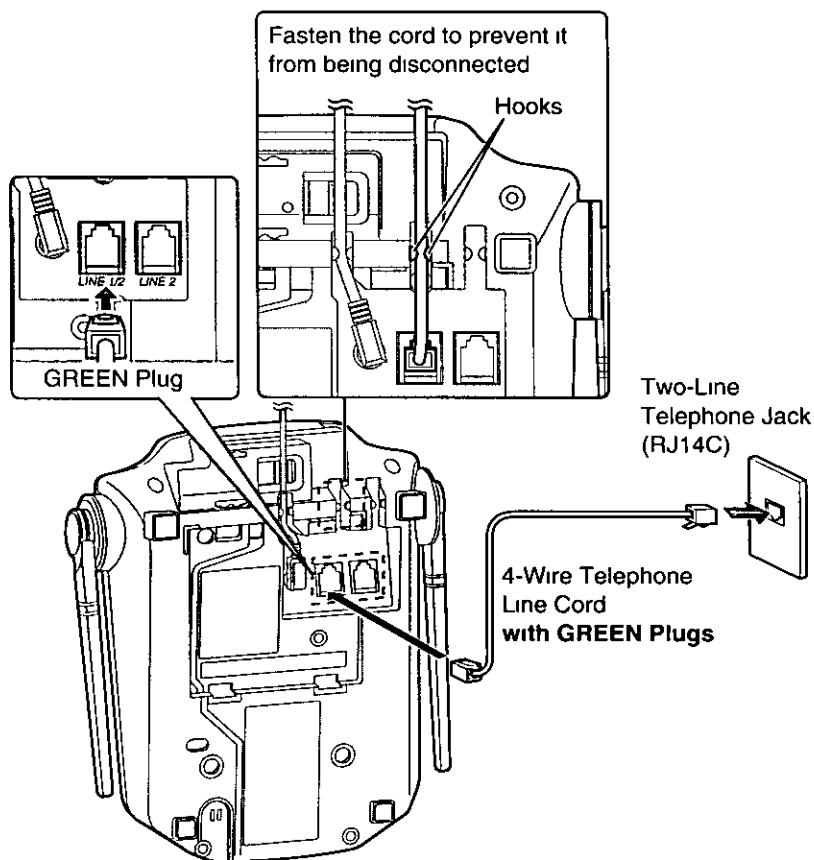

➔ Settings

To connect two single-line telephone jacks

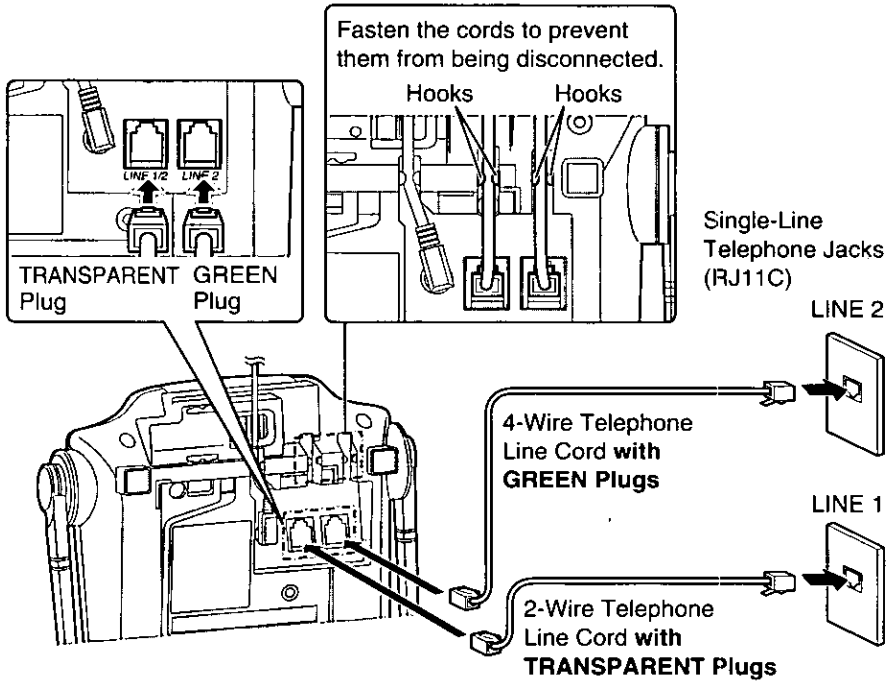

If you use the unit as a single-line telephone only

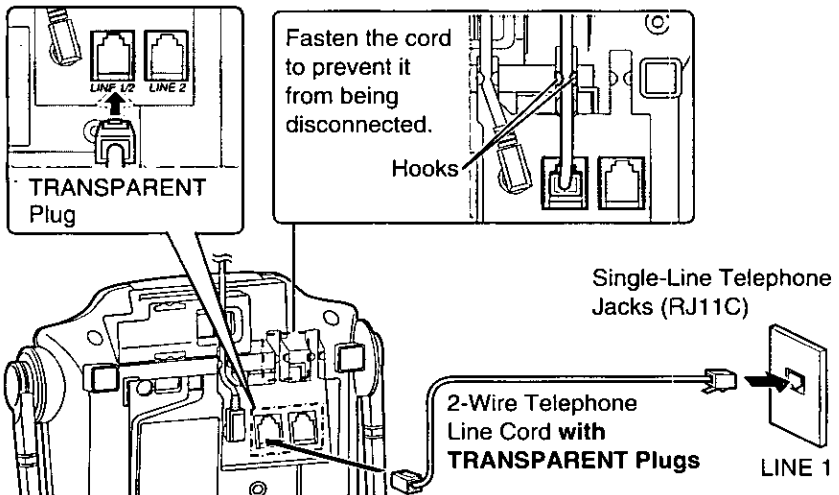



Battery Charge

Place the handset on the base unit and charge for about **6 hours** before initial use.

- The IN USE/CHARGE indicator lights and a beep sounds.

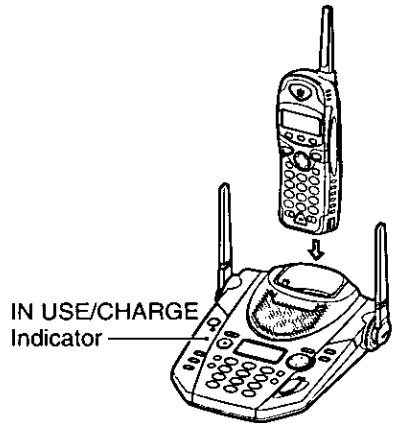

Battery strength

You can check the battery strength on the handset display while the handset is on the base unit, while it is in use (making/answering a call etc.), or after viewing the Caller List or directory items, programming etc. The battery strength will remain for a few seconds after using the handset, then the display will return to the standby mode (p. 9).

The battery strength is as shown in the chart below.

Display prompt	Battery strength
{ ■■■ }	Fully charged
{ ■■ }	Medium
{ ■ }	Low
⚡{ ■ }⚡ (flashing)	Needs to be recharged.

Recharge

Recharge the battery when:

- “Recharge battery” is displayed on the handset,
- “{ ■ }” flashes on the display, or
- the handset beeps intermittently while it is in use.

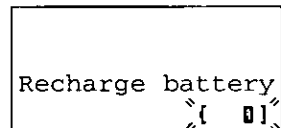

- If you DO NOT recharge the handset battery for more than 15 minutes, the display will keep indicating “Recharge battery” and/or “{ ■ }” will continue to flash.

➔ Settings

Battery information

After your Panasonic battery is fully charged (p. 13):

Operation		Approx. battery life
While in use (TALK)	near the base unit*	Up to 4.5 hours
	away from the base unit	Up to 3.5 hours
While not in use (Standby)		Up to 11 days

*Within about 10 feet (3 m)

- Battery life may be shortened depending on usage conditions, such as viewing the Caller ID Caller List or directory list, and ambient temperature.
- Clean the handset and the base unit charge contacts with a soft, dry cloth once a month. Clean more often if the unit is subject to grease, dust or high humidity.** Otherwise the battery may not charge properly.
- If the battery is fully charged, you do not have to place the handset on the base unit until "Recharge battery" is displayed and/or "{ ■ }" flashes. This will maximize the battery life.
- The battery cannot be overcharged.



Selecting the Dialing Mode

You can program the dialing mode using the handset near the base unit.

If you have touch tone service, set to "Tone". If rotary or pulse service is used, set to "Pulse". Your phone comes from the factory set to "Tone".

Make sure the unit is in the standby mode initially.

- 1 Press **FUNCTION/EXIT/CH**.

▶ Save directory
 Ringer volume
 ▼▲ ▶=Yes
- 2 Press **▼** or **▲** repeatedly until the arrow points to "Program".

▶ Program
 ▼▲ ▶=Yes
- 3 Press **FWD/EDIT** **▶** (Yes key).

▶ Save DIRECT#
 Set flash time
 ▼▲ ▶=Yes
- 4 Press **▼** or **▲** repeatedly until the arrow points to "Set dial mode".

Set line mode
 ▶ Set dial mode
 ▼▲ ▶=Yes
- 5 Press **FWD/EDIT** **▶** (Yes key).

Dial mode :Tone
 ▼▲ ▶=Save
- 6 Press **▼** or **▲** to select "Pulse" or "Tone".

Dial mode :Pulse
 ▼▲ ▶=Save
- 7 Press **FWD/EDIT** **▶** (Save key).

Dial mode :Pulse

 - A beep sounds.
 - To return to the standby mode, press **FUNCTION/EXIT/CH**.

- You can exit the programming mode any time by pressing **FUNCTION/EXIT/CH**.
- If the handset has lost communication with the base unit, 3 beeps sound and "No link to base. Place on cradle and try again." is displayed.
- If either line has rotary or pulse service, set to "Pulse". When making a call using a line which has touch tone service, press **TONE** first and then dial the number.

Selecting the Line Mode

If the line is connected to a low voltage system such as a PBX, set to "B". Otherwise the **TALK** and/or **DIGITAL SP-PHONE** button(s) may not operate properly. Both lines are preset to "A".

Use the handset near the base unit.

Make sure the unit is in the standby mode initially.

1 Press **FUNCTION/EXIT/CH**.

```
▶Save directory
  Ringer volume
▼▲           ▶=Yes
```

2 Press **▼** or **▲** repeatedly until the arrow points to "Program".

```
▶Program
▼▲           ▶=Yes
```

3 Press **FWD/EDIT** **▶** (Yes key).

```
▶Save DIRECT#
  Set flash time
▼▲           ▶=Yes
```

4 Press **▼** or **▲** repeatedly until the arrow points to "Set line mode".

```
▶Set line mode
  Set dial mode
▼▲           ▶=Yes
```

5 Press **FWD/EDIT** **▶** (Yes key).

```
Line mode
▼=Line1 ▲=Line2
```

6 Press **▼** (Line1) or **▲** (Line2) to select the line.

•The line's current setting is displayed.

```
Line mode
  Line1:A
▼▲           ▶=Save
```

7 Press **▼** or **▲** to select "B" or "A".

```
Line mode
  Line1:B
▼▲           ▶=Save
```

8 Press **FWD/EDIT** **▶** (Save key).

•A beep sounds.

•To program the other line, start again from step 4.

•To return to the standby mode, press

FUNCTION/EXIT/CH.

```
Line mode
  Line1:B
```

•You can exit the programming mode any time by pressing **FUNCTION/EXIT/CH**.

•If the handset has lost communication with the base unit, 3 beeps sound and "No link to base. Place on cradle and try again." is displayed.

Programmable Functions



You can program the following function items **using the handset near the base unit**. The display shows the programming instructions. See the corresponding pages for function details.

Make sure the unit is in the standby mode initially.

Press **FUNCTION/EXIT/CH**.



<Function menu>*

▶ Save directory	To store an item in the directory (p. 46).
Ringer volume	To select the handset ringer volume (p. 19).
Program		



Press **FWD/EDIT** .



<Function menu>*

▶ Save DIRECT#	To store a phone number in the DIRECT button (p. 43).
Set flash time	To select the flash time (p. 61).
Set line mode	To select the line mode (p. 16).
Set dial mode	To select the dial mode (p. 15).
Line selection	To change the line selection (p. 62).
Incoming call.	To select the incoming call tone (p. 63).
Talk switching	To set the auto talk feature (p. 18).
TAD program	To program answering system functions (p. 23).

During programming:

*To select a desired function item, press  or  repeatedly until the arrow points to the item. Then press **FWD/EDIT**  to go to the next step.

- You can exit the programming mode any time by pressing **FUNCTION/EXIT/CH**.
- If you do not press any buttons for 60 seconds, the unit will return to the standby mode.
- If the handset has lost communication with the base unit, 3 beeps sound and "No link to base. Place on cradle and try again." is displayed.

➔ Programmable Functions

Setting the Auto Talk Feature

The Auto Talk feature allows you to answer a call by lifting the handset off the base unit without pressing **(TALK)**. If you want to use this feature, turn the feature ON by programming. Your phone comes from the factory set to OFF.

Make sure the unit is in the standby mode initially.

1 Press **(FUNCTION/EXIT/CH)**.

2 Press **(▼)** or **(▲)** repeatedly until the arrow points to "Program".

```
▶Program
▼▲                               ▶=Yes
```

3 Press **FWD/EDIT** **(▶)** (Yes key).

4 Press **(▼)** or **(▲)** repeatedly until the arrow points to "Talk switching".

```
▶Talk switching
TAD program
▼▲                               ▶=Yes
```

5 Press **FWD/EDIT** **(▶)** (Yes key).

```
Auto talk
:Off
▼▲                               ▶=Save
```

6 Press **(▼)** or **(▲)** to select "On" or "Off".

```
Auto talk
:On
▼▲                               ▶=Save
```

7 Press **FWD/EDIT** **(▶)** (Save key).

•A beep sounds.

•To return to the standby mode, press

(FUNCTION/EXIT/CH).

```
Auto talk
:On
```

•You can exit the programming mode any time by pressing **(FUNCTION/EXIT/CH)**.

•In order to view Caller ID information before answering a call, leave the Auto Talk feature OFF.

Selecting the Ringer Volume

With the handset

You can select the handset ringer volume for each line. Set to HIGH, LOW or OFF. If set to OFF, the handset will not ring for the line(s). Your phone comes from the factory set to HIGH.

Make sure the unit is in the standby mode initially.

- 1 Press **FUNCTION/EXIT/CH**.
- 2 Press **▽** or **▲** repeatedly until the arrow points to "Ringer volume".
- 3 Press **FWD/EDIT** **▶** (Yes key).
- 4 Press **▽** (Line1) or **▲** (Line2) to select the desired line.
 - The current volume is displayed.
- 5 Press **▽** or **▲** to select the desired volume.
 - The selected volume is displayed and rings.
 - To turn the ringer OFF**, press and hold **▽** until 2 beeps sound.
 - To program the other line**, start again from step 1 after the display returns to the standby mode.

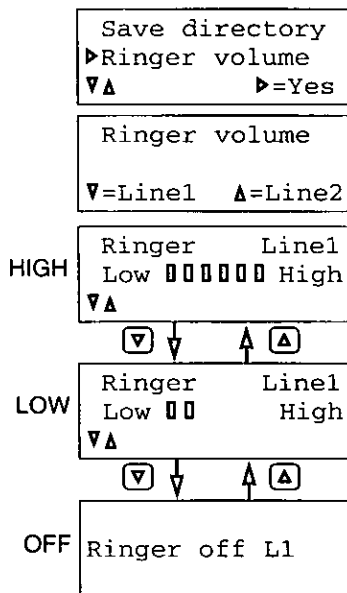

To turn the ringer ON, press **▲** or **▽** in step 5.

•The ringer for the selected line will sound at the LOW level.

- You can also select each line's ringer volume while a call is being received for the line. Press **▽** or **▲** while the unit is ringing for the line.
- When the ringer volume is set to OFF for both lines, "Ringer off L1&L2" will flash for about 45 seconds before the handset returns to the standby mode.
- When you replace the battery, the selected ringer volume setting will return to the factory set (HIGH). Reprogram if necessary.

➔ Programmable Functions

With the base unit

You can select the base unit ringer volume for each line. Set to HIGH, LOW or OFF. If set to OFF, the base unit will not ring for the line(s). Your phone comes from the factory set to HIGH.

Make sure the unit is in the standby mode initially. (You can also select each line's ringer volume while a call is being received for the line.)

To select HIGH or LOW:

- 1 Press **RINGER/CONF**
 - Both line buttons flash
- 2 For line 1 ringer volume, press **LINE 1** repeatedly until the desired volume is selected.
For line 2 ringer volume, press **LINE 2** repeatedly until the desired volume is selected.
 - Each time you press the line button, the selected ringer volume will be displayed and ring

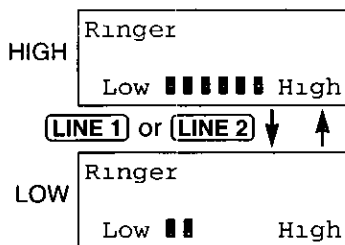

To turn the ringer OFF

Press **RINGER/CONF**, and then press and hold **LINE 1** or **LINE 2** until 2 beeps sound.

- “Ringer off L1”, “Ringer off L2” or “Ringer off L1&L2” will be displayed in the standby mode, if there are no new calls in the Caller List.

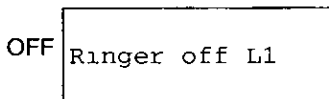

To turn the ringer ON

Press **RINGER/CONF**, and then press **LINE 1** or **LINE 2**.

- The ringer for the selected line will sound at the HIGH level.

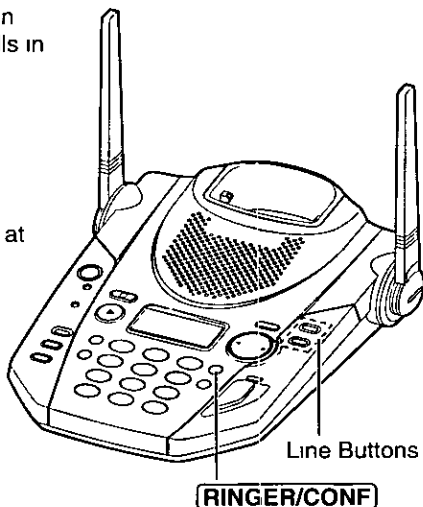

Preparing the Answering System

Preparation

Greeting Message

You can record a personal greeting message of **up to 2 minutes** for each line or a common greeting message for both lines. If a greeting message is not recorded, one of two pre-recorded greetings will be played when a call is received (p. 22).

All messages (greeting, incoming, etc.) are stored in digital memory (p. 22). The **total recording time is about 15 minutes**.

We recommend you record a **brief greeting message** (see sample on next page) in order to leave more time for recording new messages.

To record a greeting message

- 1 a) To record a common greeting, press **LINE SELECT** repeatedly until "**151 152**" is displayed.
b) To record a greeting for each line, press **LINE SELECT** repeatedly until "**151**" or "**152**" is displayed.

- 2 Press and hold **GREETING/EDIT** until a long beep is heard.

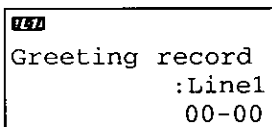

- 3 Talk clearly, about 8 inches (20 cm) away from the **MIC** (microphone).

- The base unit display shows the elapsed recording time.
- If you record for over 2 minutes, the unit will automatically stop recording.

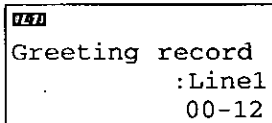

- 4 When finished, press **STOP/EXIT**.

- To check the recorded greeting, press **GREETING/EDIT** briefly.
- To change the message, start again from step 1.

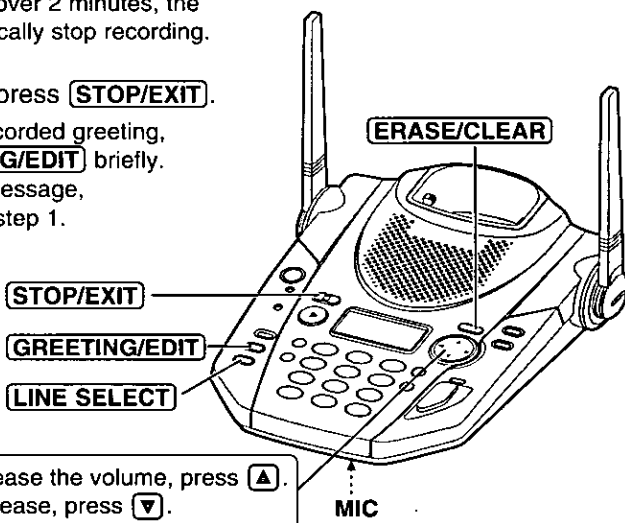

➔ Preparing the Answering System

Greeting message sample

“Hello, this is (your name and/or number). Sorry I cannot take your call. Please leave a message after the beep. Thank you.”

Pre-recorded greeting message

If you do not record a greeting message (p. 21), one of two messages will be played when a call is received, depending on the caller's recording time (p. 26).

- When the recording time is set to “1 minute” or “3 minutes”:
“Hello, we are not available now. Please leave your name and phone number after the beep. We will return your call.”
- When the recording time is set to “Greeting only”:
“Hello, we are not available now. Please call again. Thank you for your call.”

To check the greeting message(s)

Press **[LINE SELECT]** repeatedly to select the desired line(s), then press **[GREETING/EDIT]** briefly.

```
Greeting check
                :Line1
                00-10
```

- The greeting(s) is(are) played back.
- If both lines are selected and they have separate greeting messages, the LINE 1 greeting will be played first.
- To adjust the speaker volume, press **[▲]** or **[▼]**. 9 levels (0–8) are available while using the answering system.

To erase the recorded greeting message(s)

1. Press **[LINE SELECT]** repeatedly to select the desired line(s).
 2. Press **[GREETING/EDIT]** briefly.
 3. Press **[ERASE/CLEAR]** while the message is being played.
- The unit will answer a call with a pre-recorded greeting for the line(s).

Flash Memory Message Backup

Messages are stored on a “flash memory” IC chip and will not be affected by power failures. All messages are saved until you erase them.



Programming Summary for the Answering System

You can program the following functions using the handset near the base unit. Make sure the unit is in the standby mode initially.

Preparation

Press **FUNCTION/EXIT/CH**.



Press **▼** or **▲** to select "Program", and press **FWD/EDIT** **▶** (Yes key).



Press **▼** or **▲** to select "TAD program", and press **FWD/EDIT** **▶** (Yes key).

•"Answering system setting. See base unit." is displayed on the handset.



The base unit display shows programming options. Enter a required command on the display using the handset dialing buttons. See the page numbers for details.

0=Day and time	Adjusts the day and time (p. 24).
1=Remote code	Sets the remote code (p. 71).
2=Number of ring	Selects the number of rings (p. 27).
▼*		
5=Recording time	Selects the caller's recording time (p. 26).

*

*The display will change every 3 seconds.



Press **FWD/EDIT** **▶** (Save key).

- You can exit the programming mode any time by pressing **FUNCTION/EXIT/CH**.
- If you do not press any buttons for 60 seconds, the unit will return to the standby mode.
- If 6 beeps sound on the base unit during programming, a wrong key was pressed. Enter the correct number.
- If the handset has lost communication with the base unit, 3 beeps sound and "No link to base. Place on cradle and try again." is displayed on the handset.

➔ Preparing the Answering System

Day and Time Adjustment

Voice Time/Day Stamp: During playback, a synthesized voice will announce the day and time that each message was recorded.

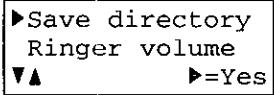
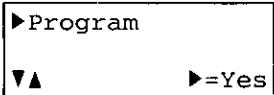
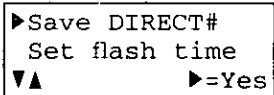
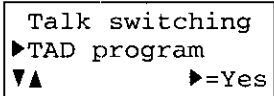
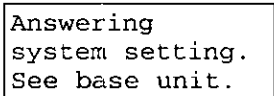
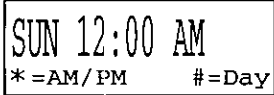
- 1 Press **FUNCTION/EXIT/CH**.

- 2 Press **▼** or **▲** repeatedly until the arrow points to "Program".

- 3 Press **FWD/EDIT** **▶** (Yes key).

- 4 Press **▼** or **▲** repeatedly until the arrow points to "TAD program".

- 5 Press **FWD/EDIT** **▶** (Yes key).
•The base unit display shows programming options.

- 6 Press **0**.
•"Set time" is announced.
If previously adjusted, the day/time will be heard.
Base unit display

- 7 Enter the time (hour and minute) using a 4-digit number.
(Ex. To set 9:30, enter "0930".)
- 8 Press ***** to select "AM" or "PM".
Press **#** repeatedly to set the day.



9

Press **FWD/EDIT**  (Save key)

- The unit announces the day/time The clock starts working
- If 6 beeps sound, the setting is not correct Start again from step 5
- To return to the standby mode, press **FUNCTION/EXIT/CH**

- In step 7, you cannot enter numbers greater than 12 **Do not use military time** (To set 13 00 hours, enter "0100", and select "PM" by pressing )

If a power failure occurs, "⊖" will flash and the incorrect day/time may be shown on the base unit display Readjust the day/time

For Caller ID service users (p 34)

- The Caller ID information will re-set the clock after the first ring if the adjusted time is incorrect However, the day will not be re-set Set the day following the procedures on pages 24 and 25
- If the time has not previously been set, the Caller ID information will not adjust the clock
- The Caller ID information will automatically adjust the clock for daylight saving time

➔ Preparing the Answering System

Selecting the Caller's Recording Time

You can select "1 minute", "3 minutes" or "Greeting only" for the caller's recording time. Your phone comes from the factory set to "3 minutes".

1 Press **FUNCTION/EXIT/CH**.

```
▶Save directory
  Ringer volume
▼▲                ▶=Yes
```

2 Press **▼** or **▲** repeatedly until the arrow points to "Program", and press **FWD/EDIT** **▶** (Yes key).

```
▶Program
▼▲                ▶=Yes
```

3 Press **▼** or **▲** repeatedly until the arrow points to "TAD program".

```
Talk switching
▶TAD program
▼▲                ▶=Yes
```

4 Press **FWD/EDIT** **▶** (Yes key).
•The base unit display shows programming options.

```
Answering
system setting.
See base unit.
```

5 Press **5**.

Base unit display

```
Recording time
1=Line1 2=Line2
```

6 To select LINE 1, press **1**.
To select LINE 2, press **2**.
•The line's current setting is displayed on the base unit.

Base unit display

```
Recording time
Line1:3min
```

7 Press **1**, **2** or **3** to select the recording time.
1: 1 minute 2: 3 minutes
3: Greeting only

8 Press **FWD/EDIT** **▶** (Save key).
•A beep sounds.
•To program the other line, start again from step 3.
•To return to the standby mode, press **FUNCTION/EXIT/CH**.

If you select "Greeting only" for the line(s), the unit will answer a call with the greeting message, and then hang up. The unit will not record any incoming messages for the line(s). If both lines are set to "Greeting only", the base unit display will show "Greeting only" in the standby mode, but the number of incoming messages will not be displayed.

Selecting the Number of Rings

You can select the number of times the unit rings before the answering system answers a call, from "2" to "7" or "Toll saver".

Your phone comes from the factory set to "Toll saver".

1 Press **FUNCTION/EXIT/CH**.

▶Save directory
Ringer volume
▼▲ ▶=Yes

2 Press ▼ or ▲ repeatedly until the arrow points to "Program", and press **FWD/EDIT** (▶) (Yes key).

▶Program
▼▲ ▶=Yes

3 Press ▼ or ▲ repeatedly until the arrow points to "TAD program".

Talk switching
▶TAD program
▼▲ ▶=Yes

4 Press **FWD/EDIT** (▶) (Yes key).

- The base unit display shows programming options.

Answering
system setting.
See base unit.

5 Press **2**.

Base unit display

Number of rings
1=Line1 2=Line2

6 To select LINE 1, press **1**.
To select LINE 2, press **2**.

- The line's current setting is displayed on the base unit.

Base unit display

Number of rings
Line1:Toll saver

7 Press **0**, or **2** to **7** to set the number of rings.

0: Selects "Toll saver".

2-7: The unit will answer after the selected number of rings.

8 Press **FWD/EDIT** (▶) (Save key).

- A beep sounds.

- To program the other line, start again from step 3.

- To return to the standby mode, press **FUNCTION/EXIT/CH**.

*Toll saver

When you call a line to which "Toll saver" is set, from a touch tone telephone: If the unit answers on the 2nd ring, there is at least one new message for the line(s). If the unit answers on the 4th ring, there are no new messages for the line(s). **Hang up when you hear the 3rd ring.** This will save you the toll charge for the call.

Making Calls

With the Handset

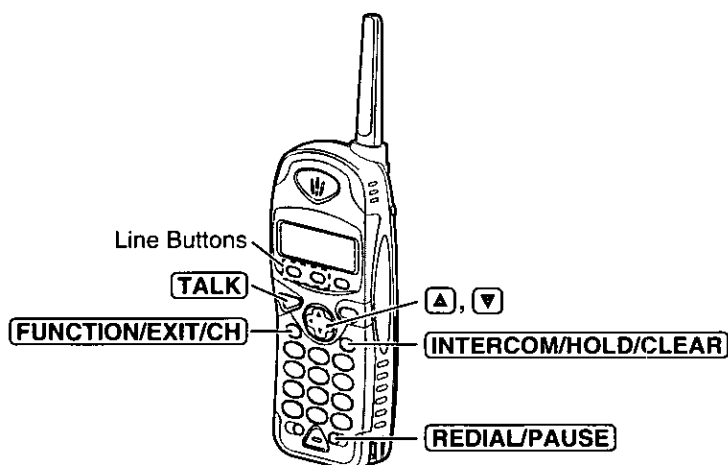

- 1** Press **TALK**.
- A free line is automatically selected and the line status icon is displayed.
 - To change the line selection, see page 62.

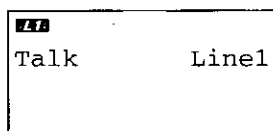

- 2** Dial a phone number.
- The dialed number is displayed.
 - After a few seconds, the display will show the length of the call and the battery strength.

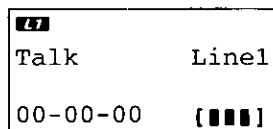
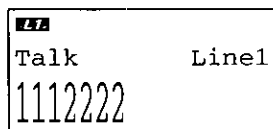

- 3** To hang up, press **TALK** or place the handset on the base unit.
- The line status icon goes out.

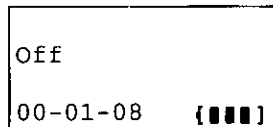

- If the handset has lost communication with the base unit, 3 beeps sound and "No link to base. Place on cradle and try again." is displayed.
- To switch a call from the handset to the speakerphone, see page 31.
- In step 1, you can select a line by pressing a line button whose status icon is not displayed, instead of pressing **TALK**.



If noise interferes with the conversation

Press **FUNCTION/EXIT/CH** to select a clearer channel or move closer to the base unit

To redial the last number dialed on the handset

Press **TALK** or a line button, and press **REDIAL/PAUSE**

To dial after confirming the entered number

1 Dial a phone number

- If you misdial, press **INTERCOM/HOLD/CLEAR** and dial again

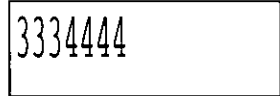

2 Press **TALK**

- You can press a line button whose status icon is not displayed, instead of pressing **TALK**
- After a few seconds, the display will show the length of the call and the battery strength

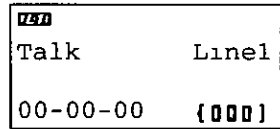
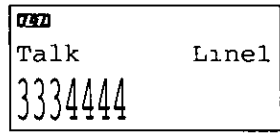

3 To hang up, press **TALK** or place the handset on the base unit

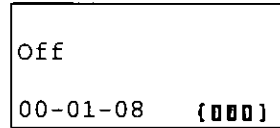

Cordless Telephone

To redial after confirming the last number dialed

Press **REDIAL/PAUSE**, and press **TALK** or a line button

To adjust the receiver volume while talking

To increase, press **▲**

To decrease press **▼**

- Each time you press **▼** or **▲**, the volume level will change
- The display will return to the length of the call

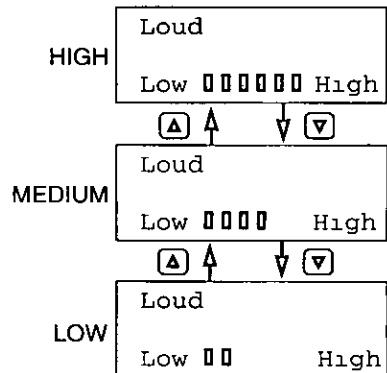

➔ Making Calls

To put a call on hold

Press **INTERCOM/HOLD/CLEAR**

- “Hold” is displayed and the line status icon on the handset flashes
- The line button on the base unit also flashes

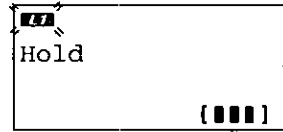

To release the hold

Press the line button on the handset whose status icon is flashing or the line button on the base unit which is flashing

- If another phone is connected on the same line (p 91), you can also release the hold by lifting its handset

Lighted handset keypad

The handset dialing buttons will light when you press a button or lift the handset off the base unit, and flash when a call is received. The lights will go out a few seconds after pressing a button, lifting the handset, answering a call, hanging up a call, leaving the programming mode or ending the intercom.

Backlit LCD display

The lighted handset display will stay on for a few seconds after pressing a handset button, lifting the handset off the base unit, hanging up a call, leaving the programming mode or ending the intercom.

What the line status icons (“**L1**” and “**L2**”) on the handset display mean

Off	The line is free
On	You are using the line on the handset, base unit or parallel connected telephone
Flashing	A call is on hold The answering system is responding to a call
Flashing quickly	A call is being received



With the Base Unit (Digital Duplex Speakerphone)

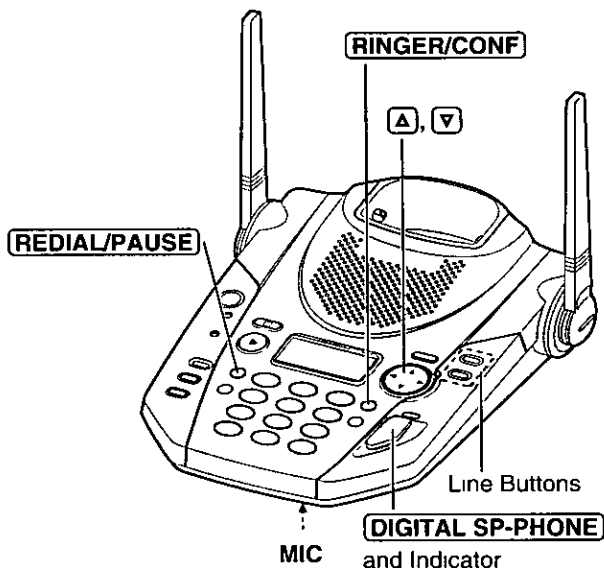

Cordless Telephone

- 1 Press **DIGITAL SP-PHONE**
 - The DIGITAL SP-PHONE indicator lights
 - A free line is automatically selected and the line button lights
- 2 Dial a phone number
 - After a few seconds, the display will show the length of the call
- 3 When the other party answers, talk into the **MIC** (microphone)
- 4 To hang up, press **DIGITAL SP-PHONE**
 - The indicator and the line button lights go out

Talk	Line1
------	-------

Talk	Line1
1112222	

Talk	Line1
00-00-00	



Off
00-01-08

- To switch to the handset while using the speakerphone
 - If the handset is off the base unit, press the line button on the handset whose status icon is on
 - If on the base unit, just lift up
- During a call using the handset, the call can be switched to the speakerphone by pressing the line button on the base unit
- The line buttons show the line status (p 32)
- In step 1, you can select a line by pressing a line button which does not light, instead of pressing **DIGITAL SP-PHONE**

➔ Making Calls

Hands-free Digital Duplex Speakerphone

For best performance, please note the following:

- Talk alternately with the caller in a quiet room.
- If the other party has difficulty hearing you, press  to decrease the speaker volume.
- If the other party's voice from the speaker cuts in/out during a conversation, press  to decrease the speaker volume.

To adjust the speaker volume (8 levels) while talking

To increase, press .

Ex. Level 8

To decrease, press .

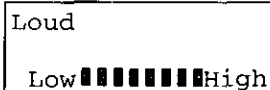

To redial the last number dialed on the base unit

Press **DIGITAL SP-PHONE** or a line button, and press **REDIAL/PAUSE**.

To put a call on hold

Press **HOLD/LOCATOR/INTERCOM**.

Hold

- The DIGITAL SP-PHONE indicator light goes out, and the line button on the base unit flashes.
- The line status icon on the handset also flashes.

To release the hold

Press the line button on the base unit which is flashing or the line button on the handset whose status icon is flashing.

- If another phone is connected on the same line (p. 91), you can also release the hold by lifting its handset.

What the base unit line buttons mean

Off	The line is free.
On	You are using the line on the base unit.
Flashing twice every 2 seconds	Someone else is using the line on the handset or parallel connected telephone.
Flashing	A call is on hold. The answering system is responding to a call.
Flashing quickly	A call is being received.

Answering Calls

When a call is received, the unit rings, "Incoming call" and the called line are displayed. The called line status icon flashes quickly on the handset display and the called line button flashes quickly on the base unit. The line is automatically selected when you answer the call. (To change the line selection, see page 62.)

If you subscribe to a Caller ID service, the calling party information will be displayed after the first ring (p. 34). In order to view the Caller ID information, please wait until the second ring to answer a call.

With the Handset

If the handset is off the base unit, press **TALK**.

- The called line status icon stops flashing.
- You can also answer a call by pressing any dialing button **0** to **9**, ***** or **#** (**Any Key Talk**).
- You can answer a call by pressing the line button instead of pressing **TALK**.

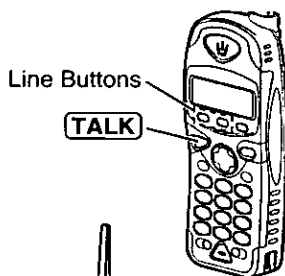

Cordless Telephone

Auto Talk

If you set the Auto Talk feature to ON (p. 18), you can answer a call by lifting the handset off the base unit without pressing **TALK**.

- When the ringer volume is set to OFF, the selected line(s) will not ring (p. 19).

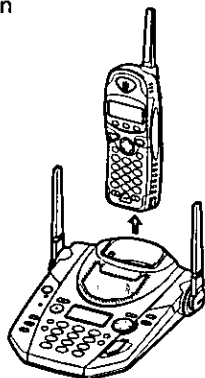

With the Base Unit (Digital Duplex Speakerphone)

- 1 Press **DIGITAL SP-PHONE**.
- 2 Talk into the **MIC**.
- 3 To hang up, press **DIGITAL SP-PHONE**.

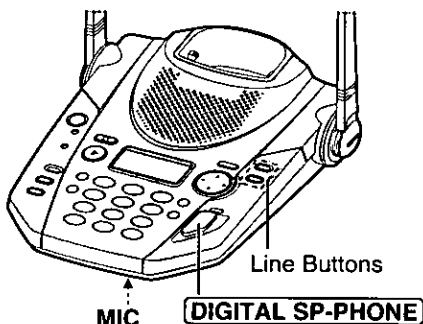

- You can answer a call by pressing the line button instead of pressing **DIGITAL SP-PHONE**.
- When the ringer volume is set to OFF, the selected line(s) will not ring (p. 20).

Caller ID Service

This unit is compatible with a Caller ID service offered by your telephone company. If you subscribe to a Caller ID service, the calling party's information will be shown on the handset and base unit displays after the first ring.

The unit can record information of up to 50 different callers for both lines combined, in the Caller List. The Caller List information is sorted by the most recent to the oldest call. When the 51st call is received, the first call is deleted.

Using the list, you can automatically call back a caller. You can store the callers' names and numbers from the Caller List into the directory.

If you subscribe to both Caller ID and Call Waiting services, when a second call is received while talking, the new caller's name and phone number will be displayed (p. 60).

How caller information is displayed when a call is received

The handset and base unit displays show the caller's name, number and the called line (1 or 2) after the first ring.

•After you answer the call, the display will show the length of the call.

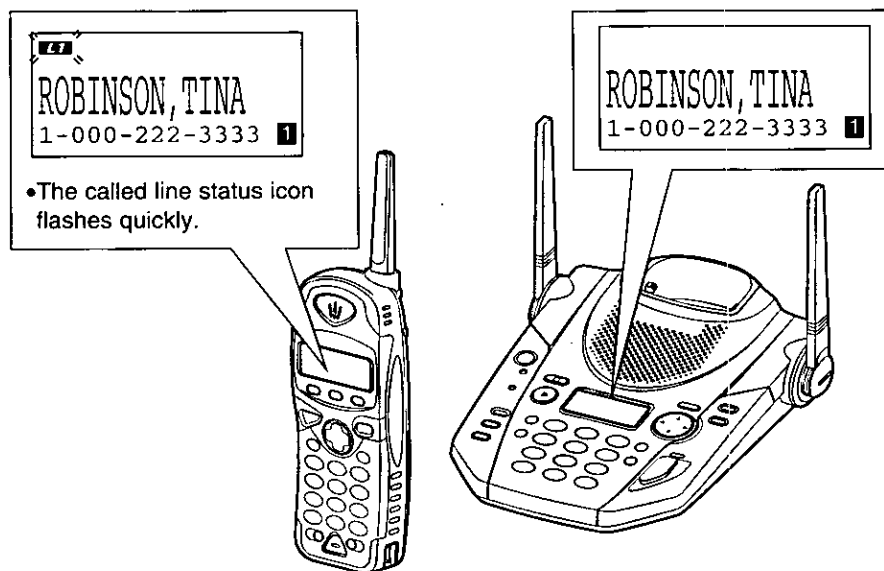

•If both lines receive calls at the same time, each caller's information will be displayed alternately.

- Caller information cannot be displayed in the following cases
 - If the caller dialed from an area which does not provide a Caller ID service, the display will show "Out of area"
 - If the caller has requested not to display his/her information, the display will show "Private caller"
- If your unit is connected to a PBX which does not support Caller ID services, you cannot access those services
- The name display service may not be available in some areas. For further information, please contact your telephone company

To check the number of new calls

When new calls have been received, the CALLER ID indicator flashes on the base unit. The handset and base unit displays show the number of new calls.

Ex. You have received 10 new calls.

While the handset is on the base unit:



Handset display

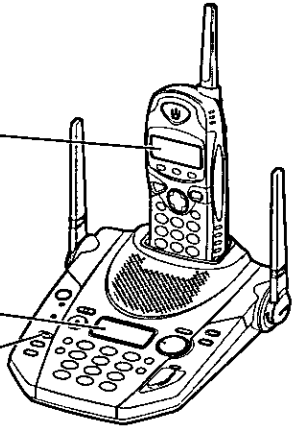

10 new calls
(000)

Base unit display

SUN 12 00AM
10 new calls
0 message



While the handset is off the base unit:
Press  or  to turn the display on

10 new calls
  =Directory

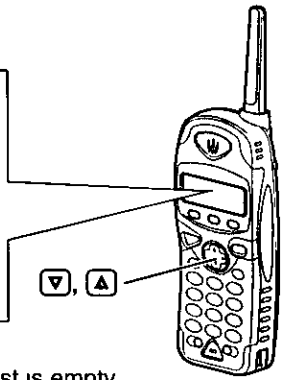

• If "No items stored" is displayed, the Caller List is empty

Using the Caller List

Viewing the Caller List

You can view the caller list with the handset or the base unit. Caller List information includes the caller's name and phone number, the called line, the time and date the call was received. If the same caller called more than once, the number of the called times is displayed (p. 37).

Make sure the unit is in the standby mode initially.

With the handset

- 1 Press **▼** or **▲** to enter the Caller List.

- The display will show, for example, the following.

```
2 new calls
▼▲ ▶=Directory
```

- You can go to the directory list by pressing **FWD/EDIT** **▶** (p. 49).

- 2 To search from the most recent call, press **▼**.
To search from the oldest call, press **▲**.

- To scroll between callers, press **▼** or **▲**.

```
SMITH, JACK
1-222-333-4444 1
3:10P JUN.10
```

- 3 To exit the list, press **FUNCTION/EXIT/CH**.

- The handset will return to the standby mode.

With the base unit

- 1 Press **▼** or **▲** to enter the Caller List.

- The display will show, for example, the following.

```
2 new calls
▼▲ ▶=Directory
```

- You can go to the directory list by pressing **▶** (p. 50).

- 2 To search from the most recent call, press **▼**.
To search from the oldest call, press **▲**.

- To scroll between callers, press **▼** or **▲**.

```
SMITH, JACK
1-222-333-4444 1
3:10P JUN.10
```

- 3 To exit the list, press **STOP/EXIT**.

- The base unit will return to the standby mode.

- Once new calls have been checked, "✓" will be added.
- If "No items stored" is displayed, the Caller List is empty.
- If there is no name information for a caller, the display will only show the phone number.
- While you are viewing the Caller List with the handset, another person cannot access the list using the base unit, and vice versa.



What "1" and "2" mean

Indication of the called line.

SMITH, JACK
1-222-333-4444 2
3:10P JUN.10 X3

What "✓" means

When the display shows "✓", you have already viewed this calling information, answered the call, called back the caller or played back the message (p. 66). If the same caller calls again, the call entry with "✓" will be replaced with the new call entry.

SMITH, JACK
1-222-333-4444 ✓
3:10P JUN.10 ✓

If a caller calls more than once

The number of times the same caller called is displayed (X2 to X9). The date and time of the most recent call will be recorded. After checking, X2 to X9 will be replaced with "✓".

SMITH, JACK
1-222-333-4444 ✓
3:10P JUN.10 X3

Cordless Telephone

Calling Back from the Caller List

With the handset

- 1 Press **▼** or **▲** to enter the Caller List.

3 new calls
▼▲ ▶=Directory

- 2 Press **▼** or **▲** repeatedly to find the desired caller.

TURNER, CINDY
1-234-456-7890 1
11:20A JAN.12 X3

- 3 Press **TALK**.
- You can also press a line button instead of pressing **TALK**.
 - The displayed phone number is dialed automatically.

With the base unit

- 1 Press **▼** or **▲** to enter the Caller List.

3 new calls
▼▲ ▶=Directory

- 2 Press **▼** or **▲** repeatedly to find the desired caller.

TURNER, CINDY
1-234-456-7890 1
11:20A JAN.12 X3

- 3 Press **DIGITAL SP-PHONE**.
- You can also press a line button instead of pressing **DIGITAL SP-PHONE**.
 - The displayed phone number is dialed automatically.

- In some cases, you may have to edit the number before dialing (p. 38, 39). (Ex. You may have to delete "1" and the area code.)
- If a phone number is not displayed in the caller information, you cannot call back that caller.

➔ Using the Caller List

Editing the Caller's Phone Number

You can edit a phone number into one of 4 patterns using the handset or the base unit.

Make sure the unit is in the standby mode initially.

With the handset

1 Press **▼** or **▲** to enter the Caller List.

```
5 new calls
▼▲ ▶=Directory
```

2 Press **▼** or **▲** repeatedly to find the desired caller, and press **FWD/EDIT** **▶**.

```
PARKER, FRED
1-234-321-5555 [1]
11:20A JAN.12 ✓
```

```
▶Edit
Save directory
▼▲ ▶=Yes
```

3 While the arrow points to "Edit", press **FWD/EDIT** **▶** (Yes key).

```
PARKER, FRED
1-234-321-5555 [1]
▼=Next ▶=Edit
```

4 Press **FWD/EDIT** **▶** (Edit key) to select a pattern.

•Each time you press **FWD/EDIT** **▶**, the number is rearranged into one of 4 different patterns.

Ⓐ Phone no.

Ⓑ Area code - Phone no.

Ⓒ 1 - Phone no.

Ⓓ 1 - Area code - Phone no.

•The order in which patterns Ⓐ-Ⓓ are displayed depends on how the telephone number is displayed in step 2.

Ⓐ 321-5555 [1] ←

Ⓑ 234-321-5555 [1]

Ⓒ 1-321-5555 [1]

Ⓓ 1-234-321-5555 [1]

5 After editing the number, you can continue with calling back or storing procedures. To call back, press **TALK** (p. 37).

To store the number in the directory, press **▼** (Next key), and press **FWD/EDIT** **▶** (Save key). (If the caller has no name information, see page 40, from step 3.)

```
PARKER, FRED
321-5555
▲=Edit ▶=Save
```

•The number edited in step 4 will not be maintained in the Caller List.



With the base unit

1 Press **▼** or **▲** to enter the Caller List.

```
5 new calls
▼▲ ▶=Directory
```

2 Press **▼** or **▲** repeatedly to find the desired caller.

```
PARKER, FRED
1-234-321-5555 [M]
11:20A JAN.12 ✓
```

3 Press **[GREETING/EDIT]** to select a pattern.

- Each time you press **[GREETING/EDIT]**, the number is rearranged into one of 4 different patterns.

- (a) **[Phone no.]**
- (b) **[Area code] - [Phone no.]**
- (c) **1 - [Phone no.]**
- (d) **1 - [Area code] - [Phone no.]**

- The order in which patterns (a)-(d) are displayed depends on how the telephone number is displayed in step 2.

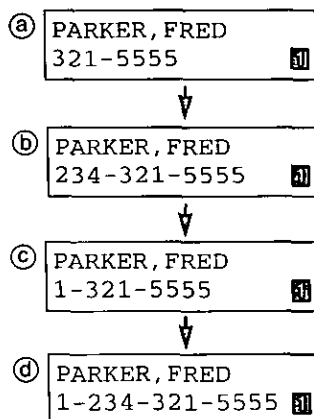

4 After editing the number, you can continue with calling back. Press **[DIGITAL SP-PHONE]** (p. 37).



- The number edited in step 3 will not be maintained in the Caller List.

➔ Using the Caller List



Storing Caller List Information in the Directory

You can store names and phone numbers that are in the Caller List into the directory. **Storing must be carried out with the handset.**

Make sure the unit is in the standby mode initially.

1 Press  or  to enter the Caller List.



```
10 new calls
▼▲ ▶=Directory
```

2 Press  or  repeatedly to find the caller you want to store in the directory, and press **FWD/EDIT**  (Yes key).

```
TURNER, CINDY
1-234-456-7890 
11:20A JAN.12 X3
```





•If the number requires editing, see page 38.

```
▶Edit
Save directory
▼▲ ▶=Yes
```

3 Press  or  to select "Save directory", and press **FWD/EDIT**  (Yes key).

```
Edit
▶Save directory
▼▲ ▶=Yes
```

If there is no name information for the caller, "Enter name" will be displayed.

- If a name is not required, press  (Next key) and press **FWD/EDIT**  (Save key).
- If a name is required, enter the name (p. 47). When finished, press  (Next key) and press **FWD/EDIT**  (Save key).

```

Enter name
☐
◀▶ ▼=Next
```

```

Enter name
CINDY TURNER
◀▶ ▼=Next
```

- A beep sounds.
- To continue storing other items, repeat from step 2.
- To return to the standby mode, press **FUNCTION/EXIT/CH**.

```

CINDY TURNER
12344567890
```

- You can exit the programming mode any time by pressing **FUNCTION/EXIT/CH**.
- If the display shows "Directory full" in step 3, press **FUNCTION/EXIT/CH** to exit the list. To erase other stored items from the directory, see page 53.
- After the maximum of 50 items has been stored, "Directory full" is also displayed.
- You cannot store caller information in the directory if a phone number is not displayed.
- If 3 beeps sound and the display shows "Save error" in step 3, move closer to the base unit and start again from step 2.



Erasing Caller List Information

After checking the Caller List, you can erase some or all of the entries with the handset or the base unit.

Make sure the unit is in the standby mode initially.

To erase a specific caller from the Caller List

With the handset:

- 1 Press **▼** or **▲** to enter the Caller List.

10 new calls
▼▲ ▶=Directory

- 2 Press **▼** or **▲** repeatedly to find the caller you want to erase from the Caller List.

REAGAN, TOM
1-888-777-6666 **■**
12:20A JAN.12 ✓

- 3 Press **INTERCOM/HOLD/CLEAR**.

Clear

- A beep sounds and the information is erased.
- To erase other items, repeat from step 2.
- To return to the standby mode, press **FUNCTION/EXIT/CH**.

With the base unit:

- 1 Press **▼** or **▲** to enter the Caller List.

10 new calls
▼▲ ▶=Directory

- 2 Press **▼** or **▲** repeatedly to find the caller you want to erase from the Caller List.

REAGAN, TOM
1-888-777-6666 **■**
12:20A JAN.12 ✓

- 3 Press **ERASE/CLEAR**.

Clear



- A beep sounds and the information is erased.
- To erase other items, repeat from step 2.
- To return to the standby mode, press **STOP/EXIT**.

➔ Using the Caller List

To erase all entries in the Caller List

Before erasing all entries, make sure that "0 new call" is displayed



With the handset:

- 1 Press  or  to enter the Caller List

```
0 new call
▼▲ ▶=Directory
```

- 2 Press **INTERCOM/HOLD/CLEAR**

```
▶Exit
All clear
▼▲ ▶=Yes
```

- 3 Press  or  to select "All clear"



```
Exit
▶All clear
▼▲ ▶=Yes
```

- 4 Press **FWD/EDIT**  (Yes key) or **INTERCOM/HOLD/CLEAR**

```
All clear
```

•A beep sounds and all entries are erased



With the base unit:

- 1 Press  or  to enter the Caller List

```
0 new call
▼▲ ▶=Directory
```

- 2 Press **ERASE/CLEAR**

```
▶Exit
All clear
▼▲ ▶=Yes
```

- 3 Press  or  to select "All clear"

```
Exit
▶All clear
▼▲ ▶=Yes
```

- 4 Press  (Yes key) or **ERASE/CLEAR**

```
All clear
```

•A beep sounds and all entries are erased

One-Touch Dialer



You can store a phone number in the **DIRECT** button of the handset. The stored number is dialed with a one-touch operation.

Storing a Phone Number in the DIRECT Button

Make sure the unit is in the standby mode initially.

- 1 Press **FUNCTION/EXIT/CH**.
- 2 Press **▽** or **△** repeatedly until the arrow points to "Program".
- 3 Press **FWD/EDIT** **▶** (Yes key).
- 4 While the arrow points to "Save DIRECT#", press **FWD/EDIT** **▶** (Yes key).
- 5 Enter a phone number, up to 22 digits.
 - Each time you press **INTERCOM/HOLD/CLEAR** the digit to the left of the cursor is erased. To erase all digits, press and hold **INTERCOM/HOLD/CLEAR**.
 - To move the cursor, press **BACK** **◀** or **FWD/EDIT** **▶**.
- 6 Press **▽** (Next key).
 - If you want to edit the entered number, press **△** (Edit key) and return to step 5.
- 7 Press **FWD/EDIT** **▶** (Save key).
 - A beep sounds.
 - To return to the standby mode, press **FUNCTION/EXIT/CH**.

▶Program	
▽△	▶=Yes

▶Save DIRECT# Set flash time	
▽△	▶=Yes

□	
◀▶	▽=Next

1234567890123456 789012	
◀▶	▽=Next

1234567890123456 789012	
▲=Edit	▶=Save

1234567890123456 789012 Save DIRECT#	
--	--

Cordless Telephone

- You can exit the programming mode any time by pressing **FUNCTION/EXIT/CH**.
- If a pause is required for dialing, **REDIAL/PAUSE** can be stored in a phone number in step 5. This counts as one digit (p. 59).

➔ One Touch Dialer

Dialing the Stored Number in the DIRECT Button

- 1 Press **DIRECT**
- The stored number is displayed

1234567890123456 789012

- 2 Press **TALK**
- You can press a line button instead of pressing **TALK**
 - The number is dialed

T2	
Talk	Line2
1234567890123456	
789012	

- You can also dial the stored number by pressing **TALK** then pressing **DIRECT** (If your line has rotary or pulse service, any access numbers stored after pressing **TONE** will not be dialed)

Using the Directory



You can store up to 50 names and phone numbers in the directory using the handset. All directory items are sorted by the first word in alphabetical order. Using the directory, you can make a call by selecting a name on the handset or base unit display.

Storing Names and Numbers in the Directory

Storing must be carried out with the handset. Make sure the unit is in the standby mode initially.

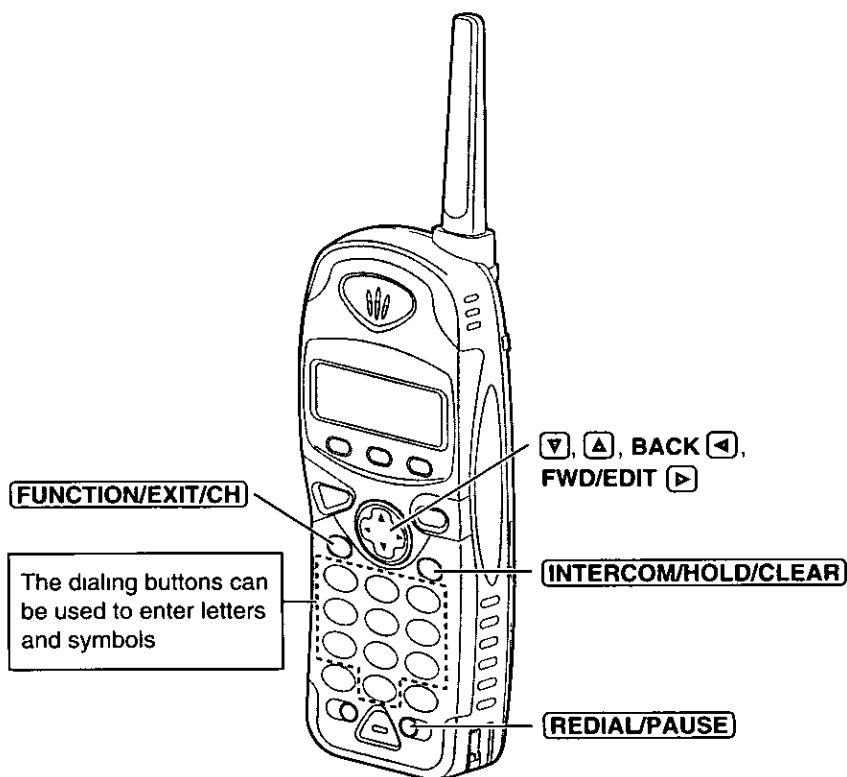

(Continued →)

➔ Using the Directory

1 Press **FUNCTION/EXIT/CH**.

▶Save directory
Ringer volume
▼▲ ▶=Yes

2 While the arrow points to "Save directory", press **FWD/EDIT** (▶) (Yes key).
•The display shows the number of stored items in the directory.

Directory=
20 items

3 Enter a name, up to 15 characters using the dialing buttons (p. 47).
•To move the cursor, press **BACK** (◀) or **FWD/EDIT** (▶).
•If a name is not required, press ▼ (Next key) and go to step 5.

Enter name
□
◀▶ ▼=Next

Enter name
Tom Jones
◀▶ ▼=Next

4 Press ▼ (Next key).

Enter phone no.

5 Enter a phone number, up to 22 digits.
•If you misdial, press **INTERCOM/HOLD/CLEAR**. Digits are erased from the right. To erase all digits, press and hold **INTERCOM/HOLD/CLEAR**.

0987654321□
◀▶ ▼=Next

6 Press ▼ (Next key).
•If you want to change the storing name or number, press ▲ (Edit key) repeatedly to reach the desired display and change it.

Tom Jones
0987654321
▲=Edit ▶=Save

7 Press **FWD/EDIT** (▶) (Save key).

- A beep sounds.
- To continue storing other items, repeat from step 2.
- To return to the standby mode, press **FUNCTION/EXIT/CH**.

- If a pause is required for dialing, **REDIAL/PAUSE** can be stored in a phone number in step 5. This counts as one digit (p. 59).
- You can exit the programming mode any time by pressing **FUNCTION/EXIT/CH**.
- If the display shows "Directory full" in step 2, press **FUNCTION/EXIT/CH** to exit the programming mode. To erase other stored items from the directory, see page 53.
- After the maximum of 50 items has been stored, "Directory full" is also displayed.
- If 3 beeps sound in step 7, the item has not been stored in the directory. Move closer to the base unit and press **FWD/EDIT** (▶) (Save key) again.



Selecting Characters to Enter Names

The handset dialing buttons (0 to 9), **BACK** ◀ and **FWD/EDIT** ▶ can be used to enter letters and symbols. The letters are printed on the dialing buttons.

Pressing each button selects a character as shown below.

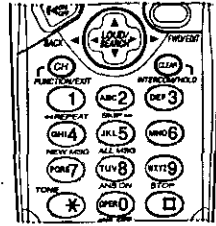

Keys	Number of times key is pressed										
	1	2	3	4	5	6	7	8	9	10	11
1	#	&	'	()	*	,	-	.	/	1
2	A	B	C	a	b	c	2				
3	D	E	F	d	e	f	3				
4	G	H	I	g	h	i	4				
5	J	K	L	j	k	l	5				
6	M	N	O	m	n	o	6				
7	P	Q	R	S	p	q	r	s	7		
8	T	U	V	t	u	v	8				
9	W	X	Y	Z	w	x	y	z	9		
0	0	Blank									
BACK ◀	To move the cursor to the left										
FWD/EDIT ▶	To move the cursor to the right										

Cordless Telephone

•To enter another character using the same dialing button, press **FWD/EDIT** ▶ to move the cursor to the next space.

If you make a mistake while entering a name

Use **BACK** ◀ or **FWD/EDIT** ▶ to move the cursor to the incorrect character, press **INTERCOM/HOLD/CLEAR** to delete and enter the correct character. Each time you press **INTERCOM/HOLD/CLEAR**, a character is erased from the right. To erase all characters, press and hold **INTERCOM/HOLD/CLEAR**.

➔ Using the Directory

For example, to enter "Tom Jones":

- 1 Press **FUNCTION/EXIT/CH**.
- 2 While the arrow points to "Save directory", press **FWD/EDIT** (▶) (Yes key).
- 3 Press **8**.
- 4 Press **6** six times, then press **FWD/EDIT** (▶) to move the cursor to the right.
- 5 Press **6** four times.
- 6 Press **FWD/EDIT** (▶) twice to enter a blank.
- 7 Press **5**.
- 8 Press **6** six times, then press **FWD/EDIT** (▶) to move the cursor to the right.
- 9 Press **6** five times.
- 10 Press **3** five times.
- 11 Press **7** eight times.
- 12 When finished, press **▼** (Next key).
 - To enter a phone number and continue storing, see page 46, from step 5.

▶Save directory
Ringer volume
▼▲ ▶=Yes

Directory=
20 items

Enter name
□
◀▶ ▼=Next

␣

To□

Tom

Tom □

Tom J

Tom Jo□

Tom Jon

Tom Jonē

Enter name
Tom Jones
◀▶ ▼=Next

Enter phone no.



Finding Items in the Directory

You can search the directory using the handset or the base unit.

Make sure the unit is in the standby mode initially.

With the handset

- 1 Press **BACK** or **FWD/EDIT** to enter the directory list.

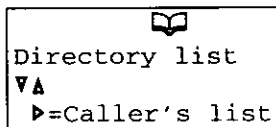

- 2 Press or .
- The first item is displayed.

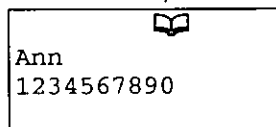

- 3 Press or repeatedly until the desired item is displayed.
- All directory items are stored in the order shown on the right.

To search for a name by initial

- ① Press the dialing button for the first letter of the desired name until any name with the same initial is displayed (see the Index table on page 51).

Ex. To find "Frank", press **3** repeatedly until the first item under "F" is displayed.

- ② Press repeatedly until the name is displayed.

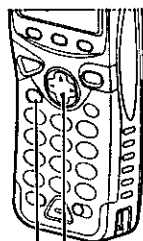

, , **BACK** ,
FWD/EDIT
FUNCTION/EXIT/CH

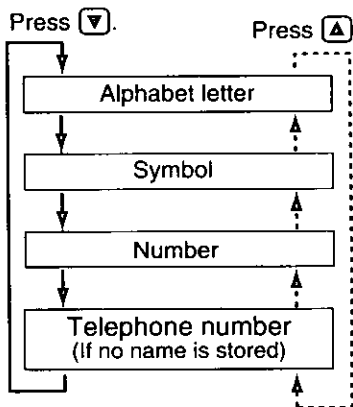

Cordless Telephone

- You can leave the directory list any time by pressing **FUNCTION/EXIT/CH**.
- If "No items stored" is displayed in step 2, the directory is empty.
- In step 1, you can go to the Caller List by pressing **FWD/EDIT** (p. 36).
- If you are viewing the directory with the handset, another person cannot access the directory using the base unit.

➔ Using the Directory

With the base unit

- 1 Press or to enter the directory list.

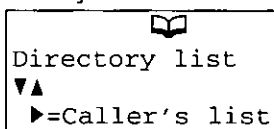

- 2 Press or .
- The first item is displayed.

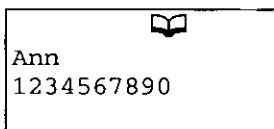

- 3 Press or repeatedly until the desired item is displayed.
- All directory items are stored in the order shown on the right.

To search for a name by initial

- ① Press the dialing button for the first letter of the desired name until any name with the same initial is displayed (see the Index table on page 51).

Ex. To find "Frank", press repeatedly until the first item under "F" is displayed.

- ② Press repeatedly until the name is displayed.

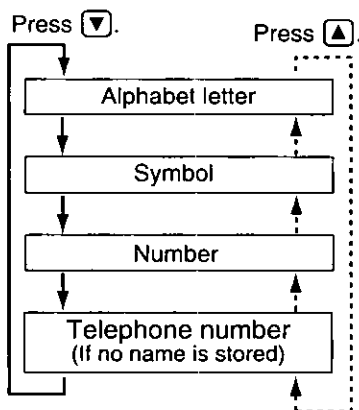
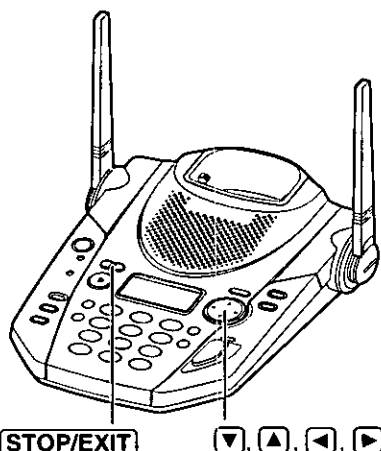

- You can leave the directory list any time by pressing **STOP/EXIT**.
- If "No items stored" is displayed in step 2, the directory is empty.
- In step 1, you can go to the Caller List by pressing (p. 36).
- If you are viewing the directory with the base unit, another person cannot access the directory using the handset.



Index table

Keys	Index	Keys	Index
①	Other symbols, 1	⑥	M, N, O, 6
②	A, B, C, 2	⑦	P, Q, R, S, 7
③	D, E, F, 3	⑧	T, U, V, 8
④	G, H, I, 4	⑨	W, X, Y, Z, 9
⑤	J, K, L, 5	⑩	0

Dialing from the Directory

Make sure the unit is in the standby mode initially.

With the handset

- 1 Press **BACK** (◀) or **FWD/EDIT** (▶) to enter the directory list.

Directory list
 ▼▲
 ▶=Caller's list

- 2 Press (▼) or (▲).
 - The first item is displayed.
- 3 Press (▼) or (▲) repeatedly to find the directory item that you want to dial.
 - To search for the item by initial, see page 49.

Frank
 4567890

- To exit the directory, press **FUNCTION/EXIT/CH**.
- 4 Press **TALK**.
 - You can also press a line button instead of pressing **TALK**.
 - The number is dialed automatically.

With the base unit

- 1 Press (◀) or (▶) to enter the directory list.

Directory list
 ▼▲
 ▶=Caller's list

- 2 Press (▼) or (▲).
 - The first item is displayed.
- 3 Press (▼) or (▲) repeatedly to find the directory item that you want to dial.
 - To search for the item by initial, see page 50.

Frank
 4567890

- To exit the directory, press or **STOP/EXIT**.
- 4 Press **DIGITAL SP-PHONE**.
 - You can also press a line button instead of pressing **DIGITAL SP-PHONE**.
 - The number is dialed automatically.

➔ Using the Directory

Editing an Item in the Directory

Programming must be carried out with the handset.
Make sure the unit is in the standby mode initially.

- 1 Press **BACK** (◀) or **FWD/EDIT** (▶) to enter the directory list.
- 2 Press (▼) or (▲).
 - The first item is displayed.
- 3 Press (▼) or (▲) repeatedly to find the directory item you want to change, and press **FWD/EDIT** (▶).
 - To search for the item by initial, see page 49.
 - If you do not need to change the name, go to step 5.
- 4 Edit the name using the dialing buttons, **BACK** (◀) or **FWD/EDIT** (▶) (p. 47), up to 15 characters.
- 5 Press (▼) (Next key).
 - If you do not need to change the number, go to step 7.
- 6 Add a number to the current number.
 - Pressing **(INTERCOM/HOLD/CLEAR)** erases the digit to the left of the cursor. To erase all digits, press and hold **(INTERCOM/HOLD/CLEAR)**.
- 7 Press (▼) (Next key).
 - If you want to change the storing name or number, press (▲) (Edit key) repeatedly to reach the desired display and change it.
- 8 Press **FWD/EDIT** (▶) (Save key).
 - A beep sounds.
 - To continue editing other items, repeat from step 3.
 - To return to the standby mode, press **(FUNCTION/EXIT/CH)**.

```
Directory list
▼▲
▶=Caller's list
```

```
Jane
1234567
```

```
Enter name
Jane
◀▶ ▼=Next
```

```
Enter name
Jane Walker
◀▶ ▼=Next
```

```
1|234567
◀▶ ▼=Next
```

```
0981|234567
◀▶ ▼=Next
```

```
Jane Walker
0981234567
▲=Edit ▶=Save
```

```
Jane Walker
0981234567
```

•You can exit the programming mode any time by pressing **(FUNCTION/EXIT/CH)**.

Erasing an Item from the Directory

Make sure the unit is in the standby mode initially

With the handset

- 1 Press **BACK** (◀) or **FWD/EDIT** (▶) to enter the directory list

Directory list
▼▲
▶=Caller's list

- 2 Press (▼) or (▲)
 - The first item is displayed
- 3 Press (▼) or (▲) repeatedly to find the directory item you want to erase
 - To search for the item by initial, see page 49

Helen
1234567890

- 4 Press **INTERCOM/HOLD/CLEAR**
 - To stop erasing, press **BACK** (◀) (No key)

Clear?
◀=No ▶=Yes

- 5 Press **FWD/EDIT** (▶) (Yes key) or **INTERCOM/HOLD/CLEAR**

Clear

- A beep sounds and the item is erased
- To erase other items, repeat from step 3
- To return to the standby mode, press **FUNCTION/EXIT/CH**

With the base unit

- 1 Press (◀) or (▶) to enter the directory list

Directory list
▼▲
▶=Caller's list

- 2 Press (▼) or (▲)
 - The first item is displayed
- 3 Press (▼) or (▲) repeatedly to find the directory item you want to erase
 - To search for the item by initial, see page 50

Helen
1234567890

- 4 Press **ERASE/CLEAR**
 - To stop erasing, press (◀) (No key)

Clear?
◀=No ▶=Yes

- 5 Press (▶) (Yes key) or **ERASE/CLEAR**

Clear

- A beep sounds and the item is erased
- To erase other items, repeat from step 3
- To return to the standby mode, press **STOP/EXIT**

Cordless Telephone

Using the Other Line During a Conversation

While Someone Else is Using a Line (Simultaneous Base/Handset Calling)

The handset and base unit can be used at the same time on separate telephone lines.

To make a call with the handset

- 1** Ex: If the base unit is using
LINE 1
Press the other line button
(LINE 2) on the handset or
TALK.
•“**L2**” is displayed.
- 2** Dial a telephone number.
- 3** To hang up, press **TALK** or
place the handset on the
base unit.

To answer a call with the handset

- 1** Ex: If the base unit is using
LINE 1
Press the other line button
(LINE 2) on the handset or
TALK.
- 2** To hang up, press **TALK** or
place the handset on the
base unit.

To make a call with the base unit

- 1** Ex: If the handset is using
LINE 1
Press the other line button
(LINE 2) on the base unit or
DIGITAL SP-PHONE.
•The DIGITAL SP-PHONE
indicator and the LINE 2 button
light.
- 2** Dial a telephone number.
- 3** To hang up, press
DIGITAL SP-PHONE.

To answer a call with the base unit

- 1** Ex: If the handset is using
LINE 1
Press the other line button
(LINE 2) on the base unit or
DIGITAL SP-PHONE.
- 2** To hang up, press
DIGITAL SP-PHONE.

- If another phone is connected on either line, you can also use it while the handset or base unit is using the other line.
- If the line selection is not set to “Auto” (p. 62), press the line button in step 1.

While You are Using a Line

During a conversation, if **two tones** sound, and the other line status icon on the handset and the other line button on the base unit flash quickly, an incoming call is being received on that line. You can answer the second call while holding the first call. You can also make a call without terminating the first call.

If you subscribe to a Caller ID service, the second caller's information will be displayed when a call is being received on the other line (p. 34).

You can delete the **two tones** (incoming call tone) by programming. See page 63.

With the handset

- 1** Ex: If you are using **LINE 1**
Press **INTERCOM/HOLD/CLEAR** to put the first call (LINE 1) on hold
 - “**L1**” flashes on the display
- 2** Press the other line button (LINE 2) to make or answer a second call
 - “**L2**” is displayed
- 3** To return to the first call (LINE 1), press the line button for the first call (LINE 1)
 - The second call is terminated

With the base unit

- 1** Ex: If you are using **LINE 1**
Press **HOLD/LOCATOR/INTERCOM** to put the first call (LINE 1) on hold
 - The LINE 1 button flashes
- 2** Press the other line button (LINE 2) to make or answer a second call
 - The LINE 2 button lights
- 3** To return to the first call (LINE 1), press the line button for the first call (LINE 1)
 - The second call is terminated

- To hold the second call in step 3, press **INTERCOM/HOLD/CLEAR** or **HOLD/LOCATOR/INTERCOM** before pressing the line button for the first call

Conference Call

While having a conversation on one line, you can make or answer a second call on the other line and then combine the calls to make a conference call

With the handset

- 1 Ex: If you are using LINE 1**
Press **INTERCOM/HOLD/CLEAR** to put the first call (LINE 1) on hold
 - “**L1**” flashes on the display
- 2** Press the other line button (LINE 2) to make or answer a second call
 - “**L2**” is displayed
- 3** When the second call is connected, press **CONF** to make a conference call
 - “Conference” is displayed and “**L1**” stops flashing

With the base unit

- 1 Ex: If you are using LINE 1**
Press **HOLD/LOCATOR/INTERCOM** to put the first call (LINE 1) on hold
 - The LINE 1 button flashes
- 2** Press the other line button (LINE 2) to make or answer a second call
 - The LINE 2 button lights
- 3** When the second call is connected, press **RINGER/CONF** to make a conference call
 - “Conference” is displayed and the LINE 1 button light stops flashing

During a conference call using the handset

- To hang up both lines, press **TALK**
- To hang up only one line, press the line button for the party with which you want to continue talking
- To put both lines on hold, press **INTERCOM/HOLD/CLEAR**
To talk with only one caller, press the corresponding line button
To resume both lines, press **CONF**

During a conference call using the base unit

- To hang up both lines, press **DIGITAL SP-PHONE**
- To hang up only one line, press the line button for the party with which you want to continue talking
- To put both lines on hold, press **HOLD/LOCATOR/INTERCOM**
To talk with only one caller, press the corresponding line button
To resume both lines, press **RINGER/CONF**



A 2-way intercom is possible between the handset and the base unit.

Paging the base unit from the handset

- 1 Handset:**
Press **INTERCOM/HOLD/CLEAR**.
Talk to the paged party* after the beeps.
•“Intercom” is displayed.

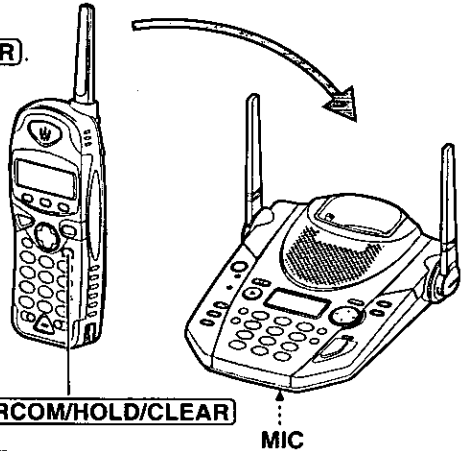

- 2 Base unit:**
When the other party's voice is heard, answer using the **MIC**.

- 3 Handset:**
To end the intercom, press **INTERCOM/HOLD/CLEAR**.

Paging the handset from the base unit (Handset locator)

Using this feature, you can locate a misplaced handset.

- 1 Base unit:**
Press **HOLD/LOCATOR/INTERCOM**.
•“Paging” is displayed on the base unit.
•The handset beeps for 1 minute and “Paging Press INTERCOM” is displayed.
•To stop paging, press **HOLD/LOCATOR/INTERCOM** again.



- 2 Handset:**
Press **INTERCOM/HOLD/CLEAR** to answer.
•“Intercom” is displayed.

- 3 Base unit:**
Talk into the **MIC**.

- 4 Handset:**
To end the intercom, press **INTERCOM/HOLD/CLEAR**.

Cordless Telephone

During an intercom call:

- Intercom calls can only be ended with the handset
- If the handset user has difficulty hearing the base unit user, decrease the base unit speaker volume by pressing **▼** on the base unit
- If an incoming call is received, the intercom call stops and the unit starts to ring. To answer, press **TALK**, **DIGITAL SP-PHONE** or the called line button

Transferring a Call Using the Intercom

The intercom can be used during a call. This feature enables you to transfer a call between the handset and the base unit.

From the handset to the base unit

- 1 Handset**
During a call, press **INTERCOM/HOLD/CLEAR**
 - The call is put on hold and "Hold" is displayed
- 2 Handset**
Press **INTERCOM/HOLD/CLEAR** again. Talk to the paged party after the beeps.
 - "Intercom hold" is displayed
 - If the base unit user does not answer, press the line button whose status icon is flashing
- 3 Base unit**
When the paging party's voice is heard, answer using the **MIC**
- 4 Base unit**
To answer the call, press the line button which is flashing
 - The transfer is complete

From the base unit to the handset

- 1 Base unit**
During a call, press **HOLD/LOCATOR/INTERCOM**
 - The call is put on hold
- 2 Base unit**
Press **HOLD/LOCATOR/INTERCOM** again.
 - "Paging Press INTERCOM" is displayed on the handset
 - If the handset user does not answer, press the line button which is flashing
- 3 Handset**
Press **INTERCOM/HOLD/CLEAR** to answer the page.
 - "Intercom hold" is displayed
- 4 Handset**
To answer the call, press the line button whose status icon is flashing
 - The transfer is complete

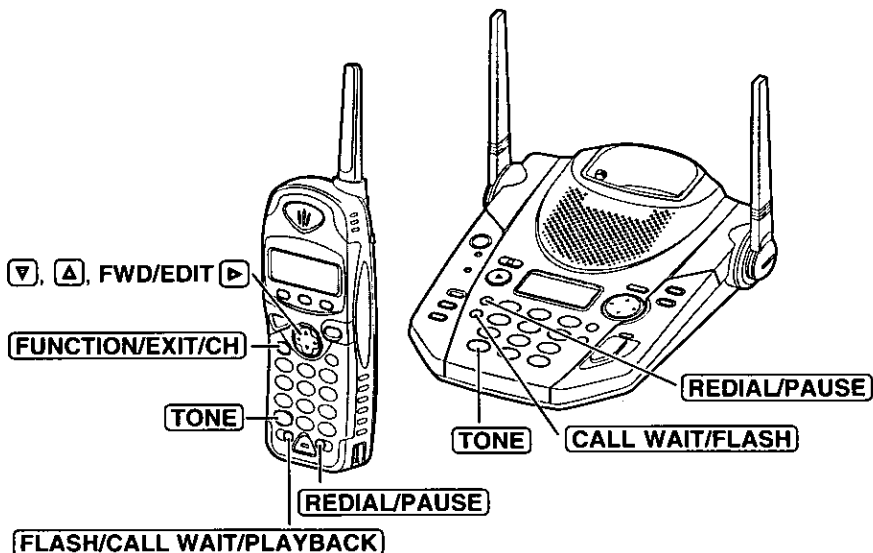

Automatic Security Code Setting

Each time you place the handset on the base unit, the unit automatically selects one of more than a million security codes. These codes help prevent the unauthorized use of your telephone line by another cordless telephone user.

How to Use the PAUSE Button (For Analog PBX Line/Long Distance Service Users)

We recommend you press **REDIAL/PAUSE** if a pause is required for dialing with a PBX or to access a long distance service.

Ex. Line access number **9** (PBX)

9 → **REDIAL/PAUSE** → Phone number

- Pressing **REDIAL/PAUSE** once creates a 3.5 second pause. This prevents misdialing when you redial or dial a stored number.
- Pressing **REDIAL/PAUSE** more than once increases the length of the pause between numbers.

➔ Special Features

For Call Waiting Service Users

If another call is received on the same line while talking, you will hear a call-waiting tone. Press **FLASH/CALL WAIT/PLAYBACK** or **CALL WAIT/FLASH** to answer the second call.

- The first call is put on hold and you can answer the second call
- To return to the first caller, press **FLASH/CALL WAIT/PLAYBACK** or **CALL WAIT/FLASH** again
- The call waiting service cannot be used when
 - the first call on the same line is placed on hold,
 - You are having a conference call (p 56),
 - the answering system is responding to the first call on the same line, or
 - a parallel connected telephone is in use
- If this function does not operate properly, consult your telephone company for details

Call Waiting Caller ID Feature

Call Waiting Caller ID Feature allows your unit to display the second caller's information. After you hear a call-waiting tone while talking, the unit will display the caller's name, the phone number, the called line (**1** or **2**) and "----Waiting-----"

BROWN, NANCY
1-000-222-3333 1
----Waiting-----

- Please contact your telephone company for details and availability in your area

Temporary Tone Dialing (For Rotary or Pulse Service Users)

Press **TONE** before entering access numbers which require tone dialing.

- The dialing mode changes to tone. You can enter numbers to access an answering service, electronic banking service, etc. When you hang up, the mode will return to pulse.
- Access numbers entered after pressing **TONE** will not be included when redialing.



FLASH Button

Pressing **FLASH/CALL WAIT/PLAYBACK** or **CALL WAIT/FLASH** allows you to use special features of your host PBX such as transferring an extension call or accessing special telephone services (optional) such as call waiting.

Selecting the flash time

The flash time depends on your telephone exchange or host PBX. You can select the following flash times: "700, 600, 400, 300, 250, 110, 100 or 90 ms (milliseconds)". Your phone comes from the factory set to "700 ms".

Make sure the unit is in the standby mode initially.

1 Press **FUNCTION/EXIT/CH**.

2 Press **▽** or **▲** repeatedly until the arrow points to "Program".

```
▶Program
▽▲                                ▶=Yes
```

3 Press **FWD/EDIT** **▶** (Yes key).

4 Press **▽** or **▲** repeatedly until the arrow points to "Set flash time".

```
Save DIRECT#
▶Set flash time
▽▲                                ▶=Yes
```

5 Press **FWD/EDIT** **▶** (Yes key).

```
Flash time
▽=Line1 ▲=Line2
```

6 Press **▽** (Line1) or **▲** (Line2) to select the desired line.

•The line's current setting is displayed.

```
Flash time
Line1:700ms
▽▲                                ▶=Save
```

7 Press **▽** or **▲** repeatedly until the desired time is displayed, and press **FWD/EDIT** **▶** (Save key).

•A beep sounds.

•To program the other line, start again from step 4.

•To return to the standby mode, press **FUNCTION/EXIT/CH**.

•You can exit the programming mode any time by pressing **FUNCTION/EXIT/CH**.

•If you are connected via a PBX, a longer flash time may be necessary to use PBX functions (transferring a call etc.). Consult your PBX supplier for the correct setting.

➡ Special Features

Line Selection

The unit will automatically select a free line which is not being used by a parallel connected telephone when you make a call. The unit will select the called line when you answer a call. To change the line selection, program as follows.

Make sure the unit is in the standby mode initially.

1 Press **FUNCTION/EXIT/CH**.

2 Press **▼** or **▲** repeatedly until the arrow points to "Program".

```
▶Program
▼▲                               ▶=Yes
```

3 Press **FWD/EDIT** **▶** (Yes key).

4 Press **▼** or **▲** repeatedly until the arrow points to "Line selection".

```
▶Line selection
  Incoming call.
▼▲                               ▶=Yes
```

5 Press **FWD/EDIT** **▶** (Yes key).

- The current selection is displayed.

Line1: LINE 1 will be selected.

Line2: LINE 2 will be selected.

Auto: A free line will be selected (LINE 1 has priority) when making a call. The called line is automatically selected when answering a call (factory preset).

```
▶Line selection
                               :Auto
▼▲                               ▶=Save
```

6 Press **▼** or **▲** repeatedly until the desired line selection is displayed.

```
▶Line selection
                               :Line2
▼▲                               ▶=Save
```

7 Press **FWD/EDIT** **▶** (Save key).

- A beep sounds.

- To return to the standby mode, press **FUNCTION/EXIT/CH**.

```
Line selection
                               :Line2
```

- You can exit the programming mode any time by pressing **FUNCTION/EXIT/CH**.
- Any line can be selected manually, regardless of the programmed line selection, by pressing that line button.

Incoming Call Tone

While one line is being used, you can be informed if another call arrives on the other line by two tones. This incoming call tone can be set/deleted by programming. Your phone comes from the factory set to "2".

Make sure the unit is in the standby mode initially

1 Press **FUNCTION/EXIT/CH**

2 Press **▼** or **▲** repeatedly until the arrow points to "Program"

▶Program
▼▲ ▶=Yes

3 Press **FWD/EDIT** **▶** (Yes key)

4 Press **▼** or **▲** repeatedly until the arrow points to "Incoming call "

Line selection
▶Incoming call
▼▲ ▶=Yes

5 Press **FWD/EDIT** **▶** (Yes key)

•The current setting is displayed

- On** The incoming call tone will be heard for as long as the other line rings
- 2** The incoming call tone will only be heard 2 times (factory preset)
- Off:** The incoming call tone will not be heard

Incoming call
tone On
▼▲ ▶=Save

6 Press **▼** or **▲** repeatedly until the desired setting is displayed

Incoming call
tone 2
▼▲ ▶=Save

7 Press **FWD/EDIT** **▶** (Save key)

- A beep sounds
- To return to the standby mode, press

FUNCTION/EXIT/CH

Incoming call
tone.2

•You can exit the programming mode any time by pressing **FUNCTION/EXIT/CH**

Automatic Answering Operation

When the unit answers a call, a greeting message is played and the caller's message is recorded. While recording, "- Answering -" and the called line icon (**L1** or **L2**) will flash on the base unit display.

- The total recording time (including greeting message) is **about 15 minutes**. If messages are recorded in noisy rooms, the time may be shortened by up to 3 minutes.
- A maximum of 64 messages (including greeting message) can be recorded.

Setting the Unit to Answer Calls

- 1 a) To turn on the answering system **on both lines**, press **LINE SELECT** repeatedly until "**L1 L2**" is displayed.
b) To turn on the answering system **on either line**, press **LINE SELECT** repeatedly until "**L1**" or "**L2**" is displayed.

- 2 Press **ANSWER ON** to turn on the answering system.

- The ANSWER ON indicator lights.
- "Answer set" and the selected line(s) will be announced.
- "**L1**" and/or "**L2**" will go out.

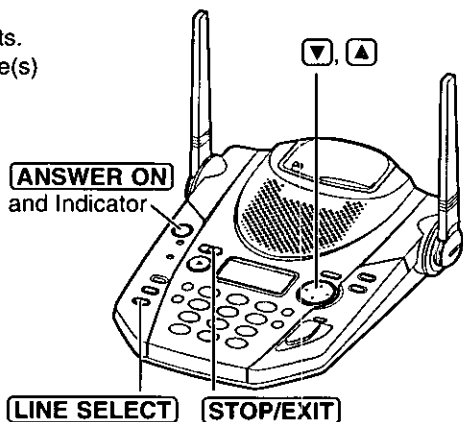

- If another button is pressed between steps 1 and 2, the selected line(s) may not be turned on.
- The unit will announce the remaining recording time if it is less than 5 minutes.
- If you hear "Memory full", "Message full" is displayed on the base unit and the ANSWER ON indicator flashes rapidly, erase some, or all, of the messages (p. 69).
- You can also turn on the answering system remotely using any other phone (p. 76).

To turn off the answering system

Press **ANSWER ON**

- The ANSWER ON indicator light goes out and “Answer off” is heard
- To turn off the answering system on either line when both lines are turned on, press **LINE SELECT** repeatedly until the line which you want to leave on is displayed, and press **ANSWER ON**

Monitoring incoming calls

While a call is being recorded, you can monitor it through the speaker. To answer the call with the speakerphone, press the line button which is flashing on the base unit. For the handset, press the line button whose status icon is flashing. The unit stops recording.

If the call monitoring feature is not required, turn it off by pressing and holding **STOP/EXIT** in the standby mode. Each time you press and hold **STOP/EXIT** in the standby mode, the feature will turn on or off.

While a call is being recorded, you can turn the feature ON by pressing **▽** or **△**.

- You can adjust the speaker volume by pressing **△** or **▽**

Listening to Messages

You can see the total number of recorded messages on the base unit display. If the ANSWER ON indicator flashes, new messages have been recorded.

Listening to only new messages

Press **NEW MESSAGE** briefly.

- The unit announces the number of new messages on the line(s) for which the answering system is on and plays them back.
- To listen to new messages on the desired line(s), press **LINE SELECT** repeatedly to select the line(s), then press **NEW MESSAGE** briefly.

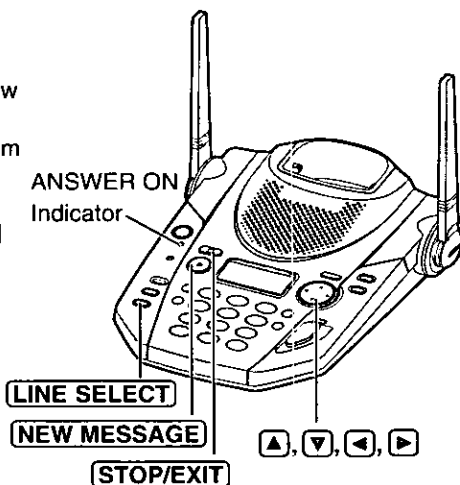

Listening to all recorded messages

Press and hold **NEW MESSAGE** until playback starts.

- The unit announces the number of all recorded messages on the line(s) for which the answering system is on and plays them back.
- To listen to all recorded messages on the desired line(s), press **LINE SELECT** repeatedly to select the line(s), then press and hold **NEW MESSAGE** until playback starts.

- If the answering system for both lines is turned on or you selected both lines by pressing **LINE SELECT**, the messages are played back from the oldest on both lines.
- During each message playback, the message number is displayed. (Ex. While the first message is being played back, “- Message 1 -” is displayed.)
- The corresponding line status icon will flash when a message on that line is being played.
- At the end of the last message, “End of final message” is heard. The unit will announce the remaining recording time if it is less than 5 minutes.



To adjust the speaker volume:

9 levels (0–8) are available while using the answering system

To increase, press **[▲]** To decrease, press **[▼]**

Ex Level 8

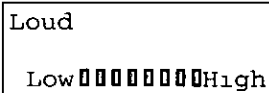

During playback

To repeat message	To repeat from the beginning of the message Press [◀] •If you press within 5 seconds of playback, the previous message will be played
To skip message	To skip to the next message Press [▶]
To stop operation	Press [STOP/EXIT] •To resume playback, press [NEW MESSAGE] •If you do not press any button for 60 seconds or if you press [STOP/EXIT] again, the unit will return to the standby mode

For Caller ID service users (p 34)

During playback, the base unit display will show the name and/or number of the caller whose message is being played

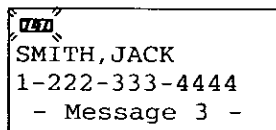

To call back the displayed number:

During playback, lift the handset and press **[TALK]** within 10 seconds, or press **[DIGITAL SP-PHONE]**

- The unit stops playback and automatically dials the displayed phone number
- You can press a line button instead of pressing **[DIGITAL SP-PHONE]** or **[TALK]**

•After listening to new incoming messages, “✓” will be added to the call entries in the Caller ID Caller List (p 37)

➔ Listening to Messages

From the Handset

If someone else is in the room and you want to listen to the recorded messages privately, you can use the handset

1 Handset

Press **FLASH/CALL WAIT/PLAYBACK**

- The number of new messages on the line(s) for which the answering system is on is heard on the handset

2 Base unit

To listen to new messages, press

NEW MESSAGE briefly

To listen to all messages, press and hold **NEW MESSAGE** until playback starts

- The messages will be heard on the handset
- ◀**, **▶** and **STOP/EXIT** can also be used during playback (p 67)



3 When finished, press

FLASH/CALL WAIT/PLAYBACK

or place the handset on the base unit

- You can also listen to messages without using the base unit See page 77

Erasing Messages

The unit will announce the remaining recording time after playback, if it is less than 5 minutes. New messages cannot be recorded when:

- “Memory full” is heard.
- “Message full” flashes on the base unit display.
- the ANSWER ON indicator flashes rapidly.

Erase some, or all, of the messages. We recommend you erase unnecessary messages after each playback.

Erasing a specific message

Press **ERASE/CLEAR** while the message(s) you want to erase is being played.

- The unit erases the message.
- A short beep will sound and the unit will continue to play the next message.

Erasing all messages

All recorded messages, except the greeting message(s), can be erased at one time.

- 1 a) To erase all messages **on both lines**, press **LINE SELECT** repeatedly until “**1L1 1L2**” is displayed.
b) To erase all messages **on either line**, press **LINE SELECT** repeatedly until “**1L1**” or “**1L2**” is displayed.

- 2 Press **ERASE/CLEAR**.
 - “Press ERASE again to erase all messages” is heard.

- 3 Within 5 seconds, press **ERASE/CLEAR** again.
 - A beep sounds, and the line(s) and “No messages” are heard.
 - The base unit display shows “0 message”.

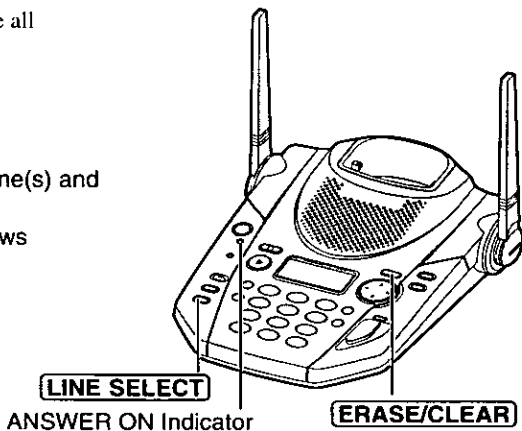

- The information in the Caller List will not be erased. To erase Caller List information, see page 41.

Remote Operation from a Touch Tone Phone

You can operate the answering system from any touch tone phone. A synthesized voice menu will guide you on how to operate the unit (p 72)

- To skip the voice menu and operate the unit directly, see page 74

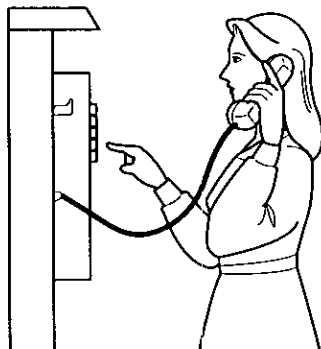

Summary of remote operation

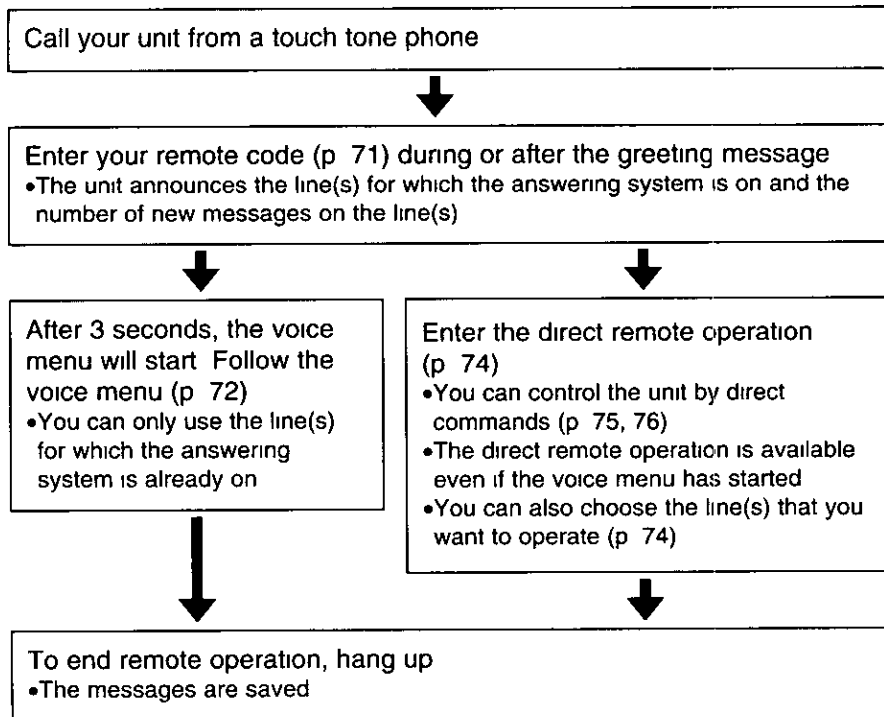

- The unit will announce the remaining recording time after playback, if it is less than 5 minutes



Setting the Remote Code

The remote code prevents unauthorized people from accessing your unit and listening to your messages. Choose any **2-digit number (00–99)**. The factory preset remote code is “11”. If you do not program your own remote code, you can use “11”.

Use the handset near the base unit. Make sure the unit is in the standby mode initially.

- 1 Press **FUNCTION/EXIT/CH**
- 2 Press **▼** or **▲** repeatedly until the arrow points to “Program”
- 3 Press **FWD/EDIT** **▶** (Yes key)
- 4 Press **▼** or **▲** repeatedly until the arrow points to “TAD program”
- 5 Press **FWD/EDIT** **▶** (Yes key)
 - The base unit display shows programming options
- 6 Press **1**
 - The current remote code is displayed on the base unit
- 7 Enter a remote code using a **2-digit number (00–99)**
- 8 Press **FWD/EDIT** **▶** (Save key)
 - A beep sounds
 - To return to the standby mode, press **FUNCTION/EXIT/CH**

▶Program
▼▲ ▶=Yes

▶Save DIRECT# Set flash time
▼▲ ▶=Yes

Talk switching
▶TAD program
▼▲ ▶=Yes

Answering system setting
See base unit

Base unit display
Remote code
11

Answering System

•If 6 beeps sound during programming, a wrong key was pressed. Enter the correct number.

To check the remote code

Repeat steps 1 to 6

•The current remote code is displayed on the base unit. When finished, press **FUNCTION/EXIT/CH**

➔ Remote Operation from a Touch Tone Phone

Voice Menu

You can operate the answering system only for the line(s) for which the answering system is already on by following the voice menu. The shaded boxes are voice prompts.

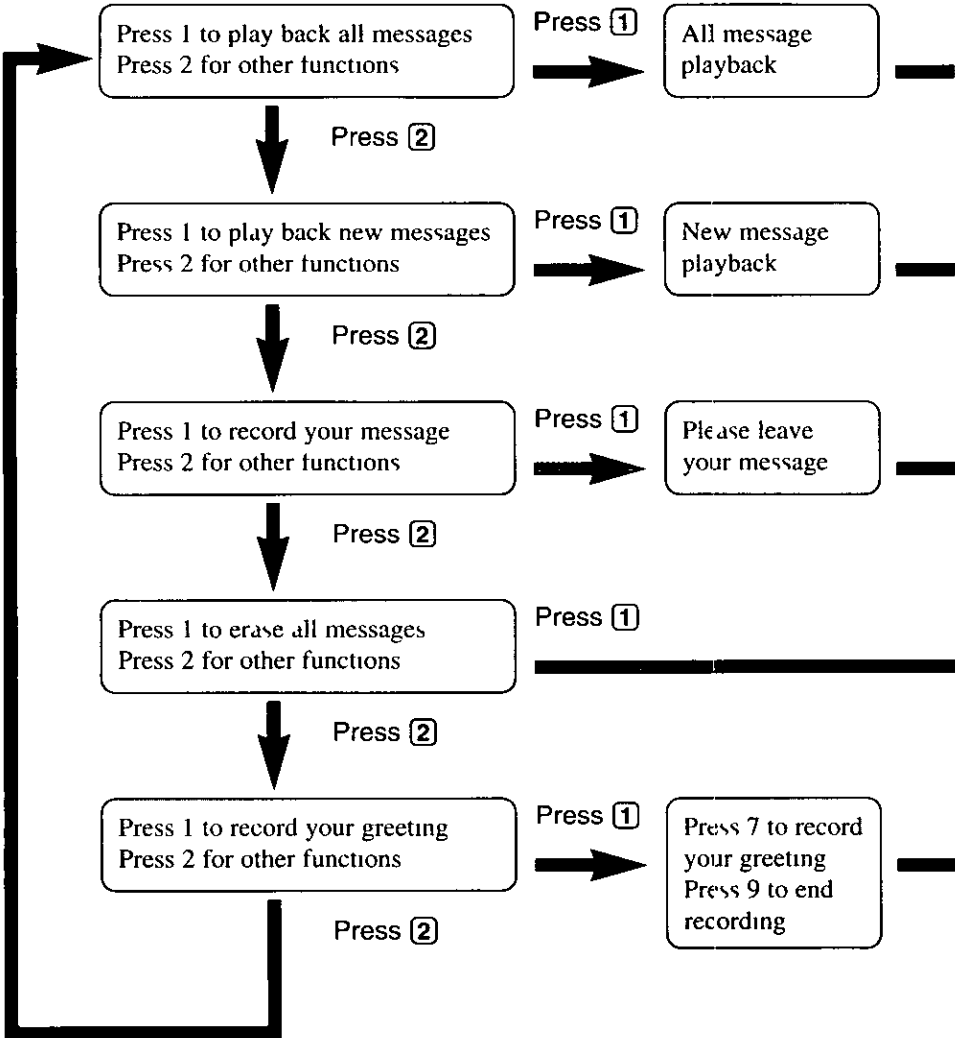



All Message Playback

All recorded messages on the line(s) for which the answering system is on are played back. At the end of the last message, "End of final message" is heard. The unit will announce the remaining recording time if it is less than 5 minutes.

New Message Playback

Only new messages on the line(s) for which the answering system is on are played back. At the end of the last message, "End of final message" is heard. The unit will announce the remaining recording time if it is less than 5 minutes.

Recording a Memo Message

You can leave a personal message.

- 1 Talk after you hear "Please leave your message"
- 2 When you finish recording, hang up

Erasing All Messages

All recorded messages on the line(s) for which the answering system is on (except greeting message) are erased.

Recording a Greeting Message

You can re-record your greeting message for the line(s) for which the answering system is on.

- 1 Press **7**
You will hear a voice prompt followed by a long beep
- 2 After the beep, talk for up to 2 minutes
- 3 When you finish recording, press **9**
- 4 Your greeting will be played back for confirmation

- 3 seconds after playback, the voice menu will start again from the beginning
- If you hear "Memory full" after playback, erase some, or all, of the messages (p 75)

➔ Remote Operation from a Touch Tone Phone

Direct Remote Operation

Once you have entered the remote code, you can also control your unit by direct commands instead of using the voice menu. To end the remote operation, hang up anytime.

Summary of direct remote operation

- 1 Select the desired line(s) after entering your remote code
To use the line(s) for which the answering system is already on, go to step 2
Press **# 1** to select "LINE 1"
Press **# 2** to select "LINE 2"
Press **# 0** to select "LINE 1 and LINE 2"
 - The number of new messages on the selected line(s) is heard



- 2 Enter the desired direct commands (p 75, 76)
 - If you do not enter any commands, the voice menu will start (p 72). You can also follow the voice menu to operate the answering system for the line(s) selected in step 1.
 - If you want to operate the other line, repeat from step 1.



- 3 To end the remote operation, hang up
 - The messages are saved
 - The line(s) that can be answered by the answering system will not change even if you select the other line in step 1. To turn on the answering system for the other line, see page 76.

•Do not press **#** for a few seconds. Some long distance services use **#** for other purposes and these services may take priority over the remote operation.



Direct commands

NEW MESSAGE PLAYBACK	4	<ul style="list-style-type: none">•Only new messages on the selected line(s) are played back
ALL MESSAGE PLAYBACK	5	<ul style="list-style-type: none">•All messages on the selected line(s) are played back
REPEAT (During playback)	1	<ul style="list-style-type: none">•The current message is repeated
SKIP (During playback)	2	<ul style="list-style-type: none">•The current message is skipped•The next message is played
STOP	9	<ul style="list-style-type: none">•Operation is stopped temporarily•To resume operation, enter a direct command within 15 seconds, or the voice menu will start
GREETING MESSAGE RECORDING	<p>You can re-record your greeting message for the selected line(s)</p> <p>7</p> <p>↓</p> <p>RECORD</p> <p>↓</p> <p>9</p>	<ul style="list-style-type: none">•A long beep sounds•After the beep, talk immediately for up to 2 minutes•The recording is stopped•The recorded message is played
ERASING A SPECIFIC MESSAGE (During playback)	* 4	<ul style="list-style-type: none">•The current message is erased•A short beep will sound and the next message will be played
ERASING ALL MESSAGES	* 5	<ul style="list-style-type: none">•All recorded messages on the selected line(s) are erased•A long beep sounds and "Line1, no messages" and/or "Line2, no messages" is/are heard

(Continued →)

➔ Remote Operation from a Touch Tone Phone

ANSWERING
SYSTEM OFF

0

- “Answer off” is heard
 - The answering system for the selected line(s) is turned off
 - The voice menu will start. To end the remote operation, hang up. To operate the other line or both lines, select the required line(s) (see below), and enter the desired direct commands
-

SELECTING
ANOTHER LINE

1

- LINE 1 is selected and the number of new messages on LINE 1 is heard

2

- LINE 2 is selected and the number of new messages on LINE 2 is heard

0

- LINE 1 and LINE 2 are selected and the number of new messages on both lines is heard
-

ANSWERING
SYSTEM ON
FOR EACH LINE

1 8

- “Answer set line 1” is heard and the LINE 1 answering system is turned on

2 8

- “Answer set line 2” is heard and the LINE 2 answering system is turned on

0 8

- “Answer set line 1 and line 2” is heard and the answering system for both lines is turned on

•If the LINE 1 (LINE 2) answering system is on and you also want to turn on the LINE 2 (LINE 1) answering system, press **# 0 8**

Turning on the answering system

Call your unit and wait for 15 rings

- The unit will answer and the greeting message will be played
- The answering system will turn on. Hang up or enter the remote code for other options
- When turning on the answering system using a rotary or pulse service telephone, you cannot enter the remote code for other options

Skipping the greeting message

After calling your unit, press ***** during the greeting message

- The unit skips the rest of the greeting message and you can start recording your message after the long beep

Remote Operation with the Handset

You can operate your answering system with the handset
The announcements and recorded messages can only be heard with the handset

FLASH/CALL WAIT/PLAYBACK

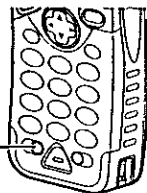

Summary of remote operation

- 1 Press **FLASH/CALL WAIT/PLAYBACK**
 - The unit announces the line(s) for which the answering system is on and the number of new messages on the line(s)
 - "Remote operation" is displayed on the handset



- 2 Select the desired line(s) To use the line(s) for which the answering system is already on, go to step 3
Press **# 1** to select "LINE 1"
Press **# 2** to select "LINE 2"
Press **# 0** to select "LINE 1 and LINE 2"
 - The number of new messages on the selected line(s) is heard
- 3 Enter the desired direct commands (p 78, 79)
 - If you want to operate the other line, repeat from step 2
 - If you do not enter a command, the voice menu will start (see next page)
 - After the voice menu, all message playback on the selected line(s) will start



- 4 To end remote operation, press **FLASH/CALL WAIT/PLAYBACK**
 - The messages are saved
 - The line(s) that can be answered by the answering system will not change even if you select the other line in step 2 To turn on the answering system for the other line, see page 79

- The unit will announce the remaining recording time after playback, if it is less than 5 minutes
- If an incoming call is received, the remote operation will be ended and the unit will start to ring To answer with the handset, press the line button whose status icon is flashing quickly
- If you hear "Memory full" after playback, erase some, or all, of the messages (p 78)

➔ Remote Operation with the Handset

Voice menu

If no commands are entered after you press

FLASH/CALL WAIT/PLAYBACK, the unit will start the following voice menu.

“Press 4 to play back new messages. Press 5 to play back all messages.”

- You can enter direct commands even if the voice menu has started.

Direct commands

NEW MESSAGE
PLAYBACK

4

- Only new messages on the selected line(s) are played back.
-

ALL MESSAGE
PLAYBACK

5

- All messages on the selected line(s) are played back.
-

REPEAT
(During playback)

1

- The current message is repeated.
 - You can also press **BACK** (◀) to repeat a message.
-

SKIP
(During playback)

2

- The current message is skipped. The next message is played.
 - You can also press **FWD/EDIT** (▶) to skip a message.
-

STOP

9

- Operation is stopped temporarily.
 - To resume operation, enter a direct command within 15 seconds, or the above voice menu will start.
-

ERASING A
SPECIFIC
MESSAGE
(During playback)

*** 4**

- The current message is erased.
 - A short beep will sound and the next message will be played.
-

ERASING ALL
MESSAGES

*** 5**

- All recorded messages on the selected line(s) are erased.
 - A long beep sounds and “Line 1, no messages” and/or “Line 2, no messages” is/are heard.
-

ANSWERING
SYSTEM ON

8

- “Answer set” is heard
- The answering system for the selected line(s) is turned on

ANSWERING
SYSTEM OFF

0

- “Answer off” is heard
- The answering system for the selected line(s) is turned off
- The voice menu will start. To end the remote operation, press **FLASH/CALL WAIT/PLAYBACK**. To operate the other line or both lines, select the required line(s) (see below), and enter the desired direct commands

SELECTING
ANOTHER LINE

1

- LINE 1 is selected and the number of new messages on LINE 1 is heard

2

- LINE 2 is selected and the number of new messages on LINE 2 is heard

0

- LINE 1 and LINE 2 are selected and the number of new messages on both lines is heard

ANSWERING
SYSTEM ON
FOR EACH LINE

1 8

- “Answer set line 1” is heard and the LINE 1 answering system is turned on

2 8

- “Answer set line 2” is heard and the LINE 2 answering system is turned on

0 8

- “Answer set line 1 and line 2” is heard and the answering system for both lines is turned on

- If the LINE 1 (LINE 2) answering system is on and you also want to turn on the LINE 2 (LINE 1) answering system, press **# 0 8**

Wall Mounting

This unit can be mounted on a wall phone plate

1 Adjust the angle of the cradle

- ① Slide the lock switch to "RELEASE"
- ② Rotate the cradle 90° until it faces straight up
- ③ Slide the lock switch to "LOCK" with the cradle facing straight up

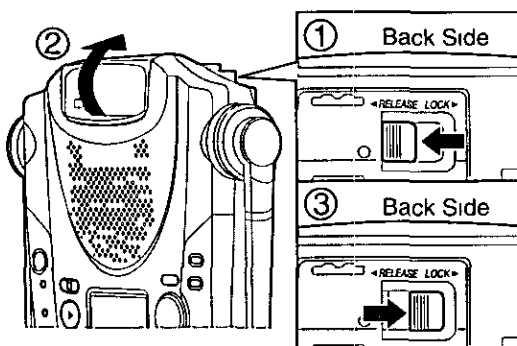

2 Connect the AC adaptor

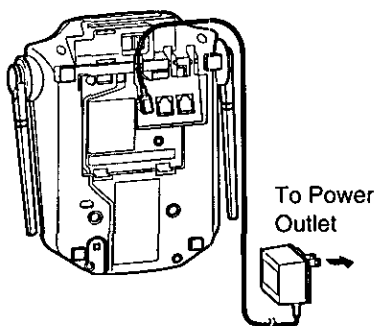

- ## 3
- ① Tuck the telephone line cord inside the wall mounting adaptor
 - ② Connect the telephone line cord to the unit
 - ③ Install the adaptor by pushing it in the direction of the arrow
 - The word "UP" should face upward

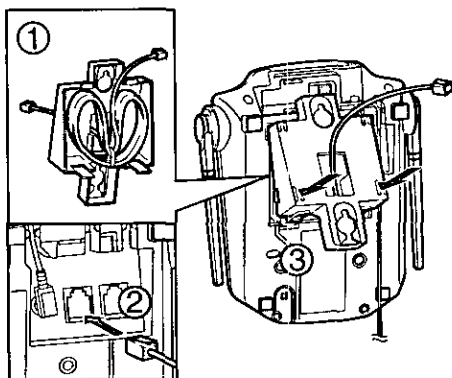

-
- 4** Connect the telephone line cord. Mount the unit, then slide down.

- Raise the antennas

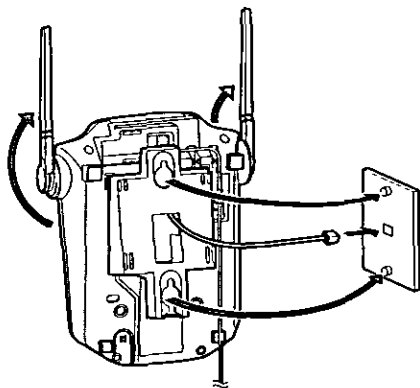

- 5** **To charge the handset battery:**
Place the handset in the cradle as shown.

- The IN USE/CHARGE indicator lights

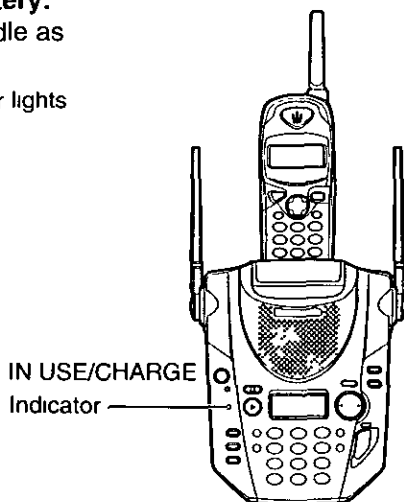

Using the Belt Clip

You can hang the handset on your belt or pocket using the belt clip.

To attach the belt clip

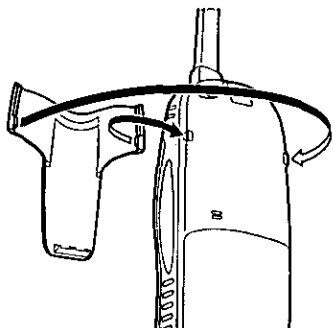

To remove the belt clip

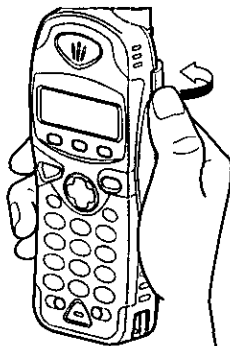

Using an Optional Headset

Plugging an optional headset into the handset allows a hands-free phone conversation. Please use only the Panasonic KX-TCA88 headset. To order call the accessories telephone number on page 2.

Connecting the headset to the handset

Open the headset jack cover, and connect the headset to the headset jack as shown below.

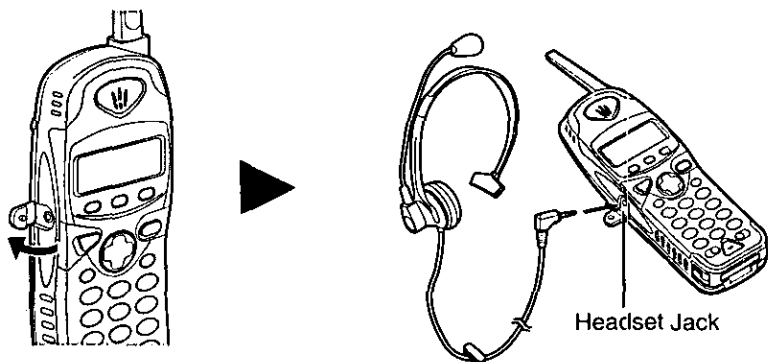

When the optional headset is connected to the handset, make sure to use the headset to talk with the caller. If you want to have a normal cordless phone conversation, disconnect the headset.

Battery Replacement

If "Recharge battery" is displayed and/or "[B]" flashes after being fully charged, replace the battery with a new Panasonic P-P510 (N4HKGMB00001) battery To order, call the accessories telephone number on page 2

- 1 **Carefully** insert a flat metal object in the slot, and push forward to release the lock Remove the handset cover

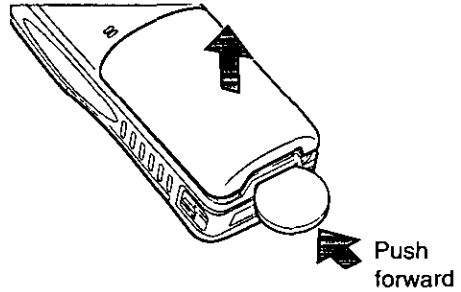

- 2 Replace the battery Then place the battery leads inside the groove, otherwise the leads may be damaged when closing the cover

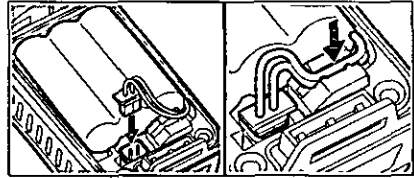

- 3 Close the cover

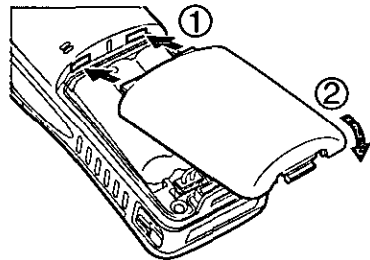

- 4 Make sure you charge the new battery for about 6 hours in order to display the battery strength prompt correctly (p 13)

Attention:

A nickel cadmium battery that is recyclable powers the product you have purchased At the end of its useful life, under various state and local laws, it is illegal to dispose of this battery into your municipal waste stream Please call 1-800-8-BATTERY for information on how to recycle this battery



If the Following Appear...

If the unit detects a problem, one of the following messages will be displayed on the handset or the base unit

Handset display

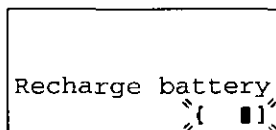

The battery needs to be charged. Place the handset on the base unit to charge the battery (p 13)

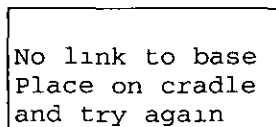

The handset has lost communication with the base unit. Place the handset on the base unit and try again.

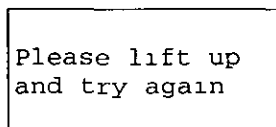

▼, **▲**, **BACK** **◀** or **FWD/EDIT** **▶** was pressed with the handset while the handset was on the base unit. Lift the handset and press the button again.

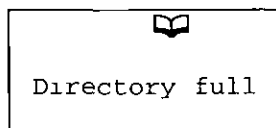

When trying to store an item or Caller List information in the directory, the directory memory is full (p 40, 46). To erase other stored items from the directory, see page 53.

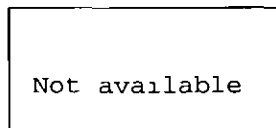

While the base unit was not in the standby mode, **▼** or **▲** was pressed to search the Caller List/directory list, **FWD/EDIT** **▶** was pressed to select an option, or **INTERCOM/HOLD/CLEAR** or **FLASH/CALL WAIT/PLAYBACK** was pressed.

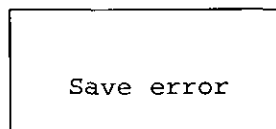

While storing items in the directory, the handset has lost communication with the base unit (p 40). Move closer to the base unit and try again.

Base unit display

SUN 10 50AM
⊖
0 message

When the clock needs adjusting, “⊖” flashes
Adjust the clock (p 24)

TEXT
Greeting record
Line1
Recording error

Your greeting message was not recorded
correctly Record it again (p 21)

SUN 12 00AM
Message full

If message memory is full, “Message full”
will flash Erase some, or all, of the messages
(p 69)

Handset in use

The display will be shown when the handset is
viewing the Caller List or directory list, and
storing directory items

Before Requesting Help

Cordless Telephone

Problem	Remedy
"No link to base Place on cradle and try again " is displayed and an alarm tone sounds	<ul style="list-style-type: none">•You are too far from the base unit Move closer and try again•Place the handset on the base unit and try again•Plug in the AC adaptor•Raise the base unit antennas
Static, sound cuts in/out, fades Interference from other electrical units	<ul style="list-style-type: none">•Locate the handset and the base unit away from other electrical appliances (p 3)•Move closer to the base unit•Raise the base unit antennas•Press [FUNCTION/EXIT/CH] to select a clearer channel
The handset and/or the base unit do not ring	<ul style="list-style-type: none">•The ringer volume is set to OFF Set to HIGH or LOW (p 19, 20)
The line status icons do not display properly and/or the line buttons on the base unit do not light properly	<ul style="list-style-type: none">•Check the settings (p 10–16)•The line mode selection is incorrect See page 16
The handset display is blank	<ul style="list-style-type: none">•The handset is in the standby mode (p 9) Press [▼], [▲], BACK [◀] or FWD/EDIT [▶] to turn the display on
The handset display is still blank after pressing [▼] , [▲] , BACK [◀] or FWD/EDIT [▶]	<ul style="list-style-type: none">•Charge the battery fully (p 13)
You cannot store a name and phone number in the directory	<ul style="list-style-type: none">•You cannot store an item in the directory while the unit is in the talk or intercom mode, or while the answering system is in use•Do not pause for over 60 seconds while storing



Problem	Remedy
While programming or searching, the unit starts to ring and stops the program/search	<ul style="list-style-type: none">•To answer the call, press (TALK), (DIGITAL SP-PHONE) or the relevant line button Start again from the beginning after hanging up
During a conversation, the other line status icon/button flashes quickly and the display shows another caller's information	<ul style="list-style-type: none">•Someone is calling you on the other line To answer, press (INTERCOM/HOLD/CLEAR) or (HOLD/LOCATOR/INTERCOM) to put the current call on hold Press the line button on the handset whose status icon is flashing quickly or the line button on the base unit which is flashing quickly (p 55)
The unit does not display the caller's name and/or phone number	<ul style="list-style-type: none">•You need to subscribe to a Caller ID service from a telephone company•Other telephone equipment may be interfering with your phone Disconnect it and try again•Other electrical appliances connected to the same outlet may be interfering with the Caller ID information•Telephone line noise may be affecting the Caller ID information
A call was received, but the caller's information was not stored in the Caller List	<ul style="list-style-type: none">•If you receive two calls at the same time, only one of the caller's information can be stored
The unit exits the Caller list/directory list while you are viewing it	<ul style="list-style-type: none">•Do not pause for over 60 seconds while searching
You cannot page the handset or the base unit	<ul style="list-style-type: none">•The handset is too far from the base unit•The handset or the base unit is engaged in an outside call, viewing the Caller List/directory list or listening to messages Try again later If you are using the base unit, wait until "Handset in use" disappears

➔ Before Requesting Help

Problem	Remedy
You cannot redial by pressing REDIAL/PAUSE	<ul style="list-style-type: none">•If the last number dialed was more than 32 digits long, the number will not be redialed correctly•Access numbers entered after pressing PHONE will not be included when redialing•The button has a double function as either redial or pause. It will redial the last number dialed if pressed at the outset of a call (p. 29, 32). If another number has been dialed first, it will operate as a pause button (p. 59).
You cannot have a conversation using the headset	<ul style="list-style-type: none">•When the headset is connected (p. 82), you must use the headset to talk with the caller. To have a normal cordless phone conversation, disconnect the headset.
You cannot have a conversation using the headset	<ul style="list-style-type: none">•Make sure that the headset is connected properly (p. 82).

Answering System

Problem	Remedy
The answering system is on, but incoming messages are not recorded	<ul style="list-style-type: none">•The recording time is set to "Greeting only." Select "1 minute" or "3 minutes" (p. 26).•Memory is full. Erase some, or all, of the messages (p. 69).•When you are talking to a caller with the speakerphone, or the answering system is responding to a call, the system will not respond to an incoming call on the other line.



Problem	Remedy
You cannot listen to the recorded messages	•Make sure that the unit is in the standby mode
"Message full" flashes on the base unit display and the ANSWER ON indicator flashes rapidly, and no new messages are recorded	•Memory is full Erase some, or all, of the messages (p 69)
You cannot operate the answering system at the base unit	•The handset user is operating the answering system Wait until the IN USE/CHARGE indicator light goes out
You cannot operate the answering system from a touch tone phone	•Make sure you enter the correct remote code •The answering system may not respond if the tones are too short to activate the unit Press each button firmly •The answering system is off Turn it on (p 76)
You cannot operate the answering system with the handset	•Someone is operating the answering system •You are too far from the base unit Move closer to the base unit •The unit is recording a message To answer the call, press the called line button whose status icon is flashing
While recording a greeting message, the unit starts to ring and stops recording	•To answer the call, press DIGITAL SP-PHONE , press TALK or the called line button Start again from the beginning after hanging up
During playback, the unit starts to ring and stops playback	•To answer the call, press DIGITAL SP-PHONE , TALK or the called line button To resume playback, press NEW MESSAGE after hanging up
The base unit does not display the name and/or number of the caller whose message is being played	•If the caller is not stored in the Caller List, the base unit will not display the caller's information

➔ Before Requesting Help

General

Problem	Remedy
The unit does not work	<ul style="list-style-type: none">•Check the settings (p 10–16)•Charge the battery fully (p 13)•Clean the charge contacts and charge again (p 14)•Install the battery properly (p 83)•Place the handset on the base unit and unplug the AC adaptor to reset. Plug in, and try again•Re-install the battery and place the handset on the base unit (p 83). Try again
You cannot program items, such as the dialing mode	<ul style="list-style-type: none">•Programming is not possible while the unit is in the talk or speakerphone mode, when viewing the Caller List/directory list, or while the answering system is in use•Do not pause for over 60 seconds while programming•Move closer to the base unit
Previously programmed information is erased	<ul style="list-style-type: none">•If a power failure occurs, programmed information may be erased. Reprogram if necessary
“Recharge battery” is displayed on the handset, “{ ■}” flashes or the unit beeps intermittently	<ul style="list-style-type: none">•Charge the battery fully (p 13)
You charged the battery fully, but “Recharge battery” is still displayed and/or “{ ■}” continues to flash	<ul style="list-style-type: none">•Clean the charge contacts and charge again (p 14)•Install a new battery (p 83)

Problem	Remedy
The IN USE/CHARGE indicator light does not go out while charging.	<ul style="list-style-type: none"> •This is normal.
If you cannot solve your problem.	<ul style="list-style-type: none"> •Call our customer call center at 1-800-211-PANA(7262). •Panasonic's e-mail address for customer inquiries: consumerproducts@panasonic.com for customers in the USA or Puerto Rico ONLY

Adding Another Phone

This unit will not function during a power failure. To connect a standard telephone on the same line, use the Panasonic T-adaptor KX-J66. To order, call the accessories telephone number on page 2.

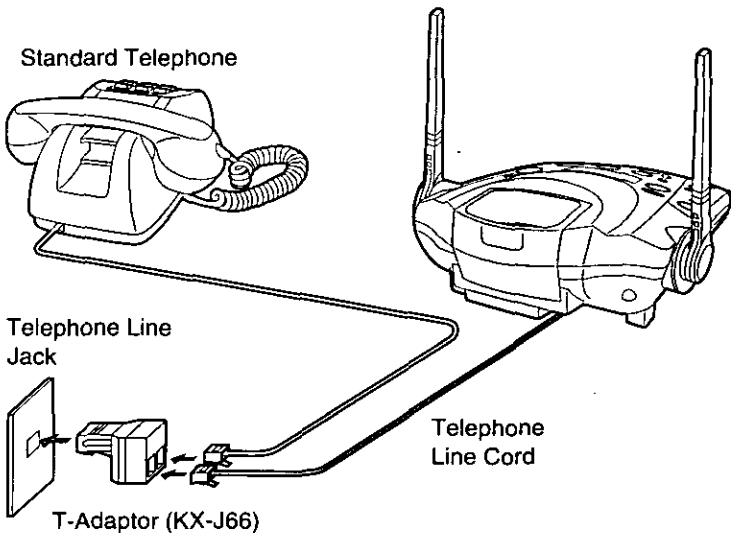

Useful Information

Important Safety Instructions

When using this unit, basic safety precautions should always be followed to reduce the risk of fire, electric shock, or personal injury.

1. Read and understand all instructions.
2. Follow all warnings and instructions marked on this unit.
3. Unplug this unit from AC outlets before cleaning. Do not use liquid or aerosol cleaners. Use a damp cloth for cleaning.
4. Do not use this unit near water, for example, near a bathtub, washbowl, kitchen sink, or the like.
5. Place this unit securely on a stable surface. Serious damage and/or injury may result if the unit falls.
6. Do not cover slots and openings on the unit. They are provided for ventilation and protection against overheating. Never place the unit near radiators, or in a place where proper ventilation is not provided.
7. Use only the power source marked on the unit. If you are not sure of the type of power supplied to your home, consult your dealer or local power company.
8. Do not place objects on the power cord. Install the unit where no one can step or trip on the cord.
9. Do not overload wall outlets and extension cords. This can result in the risk of fire or electric shock.
10. Never push any objects through slots in this unit. This may result in the risk of fire or electric shock. Never spill any liquid on the unit.
11. To reduce the risk of electric shock, do not disassemble this unit. Take the unit to an authorized servicer when service is required. Opening or removing covers may expose you to dangerous voltages or other risks. Incorrect reassembly can cause electric shock when the unit is subsequently used.
12. Unplug this unit from the wall outlet and refer servicing to an authorized servicer when the following conditions occur:
 - A. When the power supply cord or plug is damaged or frayed.
 - B. If liquid has been spilled into the unit.
 - C. If the unit has been exposed to rain or water.
 - D. If the unit does not work normally by following the operating instructions. Adjust only controls covered by the operating instructions. Improper adjustment may require extensive work by an authorized servicer.
 - E. If the unit has been dropped or physically damaged.
 - F. If the unit exhibits a distinct change in performance.
13. During thunderstorms, avoid using telephones except cordless types. There may be a remote risk of an electric shock from lightning.
14. Do not use this unit to report a gas leak, when in the vicinity of the leak.

SAVE THESE INSTRUCTIONS

CAUTION:

To reduce the risk of fire or injury to persons, read and follow these instructions

- 1 Use only the battery(ies) specified
- 2 Do not dispose of the battery(ies) in a fire. They may explode. Check with local waste management codes for special disposal instructions
- 3 Do not open or mutilate the battery(ies). Released electrolyte is corrosive and may cause burns or injury to the eyes or skin. The electrolyte may be toxic if swallowed
- 4 Exercise care in handling batteries in order not to short the battery to conductive materials such as rings, bracelets, and keys. The battery and/or conductor may overheat and cause burns
- 5 Charge the battery(ies) provided with or identified for use with this product only in accordance with the instructions and limitations specified in this manual

WARNING:

TO PREVENT FIRE OR SHOCK HAZARD, DO NOT EXPOSE THE BASE UNIT TO RAIN OR ANY TYPE OF MOISTURE. ONLY THE HANDSET IS SHOCK AND SPLASH RESISTANT

- The AC adaptor is used as the main disconnect device, ensure that the AC outlet is located/installed near the unit and is easily accessible

Splash-Resistant (HANDSET ONLY)

The handset is designed to be splash resistant
You can use the handset with wet hands

CAUTION:

- **Do not immerse in water or leave under running water**
- Keep the handset away from salt water
- Avoid exposure to prolonged high humidity
- Since water in headset jack may cause damage, close the headset jack cover when the optional headset is not in use. When the optional headset is connected, do not use the handset with wet hands
- If the handset is wet, wipe with a soft dry cloth
- The base unit is not designed to be splash resistant. Do not place the wet handset on the base unit

Shock-Resistant (HANDSET ONLY)

Although the handset is designed to be shock resistant, do not throw or step on the handset

FCC and Other Information

If requested by the telephone company, inform them as follows:

FCC Registration No. (found on the bottom of the unit)

Ringer Equivalence 0.2B

The particular telephone lines to which the equipment is connected.

This unit must not be connected to a coin operated line.

If you are on a party line, check with your local telephone company.

Ringer Equivalence No. (REN):

The REN is useful in determining the quantity of devices you may connect to your telephone line and still have all of those devices ring when your telephone number is called. In most, but not all areas, the sum of the REN's of all devices connected to one line should not exceed five (5.0). To be certain of the number of devices you may connect to your line, as determined by the REN, you should contact your local telephone company to determine the maximum REN for your calling area.

In the event terminal equipment causes harm to the telephone network, the telephone company should notify the customer, if possible, that service may be stopped.

However, where prior notice is impractical, the company may temporarily cease service providing that they:

- (a) Promptly notify the customer.
- (b) Give the customer an opportunity to correct the problem with their equipment.
- (c) Inform the customer of the right to bring a complaint to the Federal Communication Commission pursuant to procedures set out in FCC Rules and Regulations Subpart E of Part 68.

The Telephone Company may make changes in its communications facilities, equipment, operations or procedures, where such action is reasonably required in the operation of its business and is not inconsistent with the rules and regulations in FCC Part 68.

If such changes can be reasonably expected to render any customer terminal equipment incompatible with telephone company communications facilities, or require modification or alteration of such terminal equipment, or otherwise materially affect its use or performance, the customer shall be given adequate notice in writing, to allow the customer an opportunity to maintain uninterrupted service.

When programming emergency numbers and/or making test calls to emergency numbers:

1. Remain on the line and briefly explain to the dispatcher the reason for the call before hanging up.
2. Perform such activities in the off-peak hours, such as early morning hours or late evenings.

This device complies with Part 15 of the FCC Rules. Operation is subject to the following two conditions: (1) This device may not cause harmful interference, and (2) this device must accept any interference received, including interference that may cause undesired operation.

Privacy of communications may not be ensured when using this phone.

CAUTION:

Any changes or modifications not expressly approved by the party responsible for compliance could void the user's authority to operate this device.

Note

This equipment has been tested and found to comply with the limits for a Class B digital device, pursuant to Part 15 of the FCC Rules. These limits are designed to provide reasonable protection against harmful interference in a residential installation. This equipment generates, uses, and can radiate radio frequency energy and, if not installed and used in accordance with the instructions, may cause harmful interference to radio communications. However, there is no guarantee that interference will not occur in a particular installation. If this equipment does cause harmful interference to radio or television reception, which can be determined by turning the equipment off and on, the user is encouraged to try to correct the interference by one or more of the following measures:

- Reorient or relocate the receiving antenna
- Increase the separation between the equipment and receiver
- Connect the equipment into an outlet on a circuit different from that to which the receiver is connected
- Consult the dealer or an experienced radio/TV technician for help

Some cordless telephones operate at frequencies that may cause interference to nearby TVs and VCRs. To minimize or prevent such interference, the base of the cordless telephone should not be placed near or on top of a TV or VCR. If interference is experienced, move the cordless telephone further away from the TV or VCR. This will often reduce, or eliminate, interference.

Operating near 2.4GHz electrical appliances may cause interference. Move away from the electrical appliances and/or press the CH (Channel) button.

- **Environment** — do not place the unit in a room where the temperature is less than 5°C (41°F) or greater than 40°C (104°F). Allow 10 cm (4") clearance around the unit for proper ventilation. Avoid excessive smoke, dust, mechanical vibration, shock, or direct sunlight.
- **Medical** — consult the manufacturer of any personal medical devices, such as pacemakers, to determine if they are adequately shielded from external RF (radio frequency) energy. (The unit operates in the frequency range of 2401MHz to 2472MHz, and the power output level can range from 0.001 watts to 0.20 watts.) Do not use the unit in health care facilities if any regulations posted in the area instruct you not to do so. Hospitals or health care facilities may be using equipment that could be sensitive to external RF (radio frequency) energy.
- **Routine care** — wipe the unit with a soft cloth. Do not use benzine, thinner, or any abrasive powder. When you leave the unit unused for a long period of time, unplug the AC adaptor from the outlet.
- **If there is any trouble** — disconnect the unit from the telephone line and connect a known working phone. If the known working phone operates properly, have your unit repaired by one of the authorized Panasonic Factory Service Centers. If the known working phone does not operate properly, consult your telephone company.

CAUTION

To comply with FCC RF exposure requirements, the base unit should be installed with its antenna located at 20 cm or more from persons and handset should be carried with the specific belt-clip provided for the handset to ensure compliance. Other non-tested belt-clips or similar body-worn accessories may not comply, therefore, should be avoided.

For product service

- Panasonic Servicenters are listed in the servicenter directory
- Call 1-800-211-PANA(7262) for the location of an authorized servicenter
- Panasonic's e-mail address for customer inquiries
consumerproducts@panasonic.com
for customers in the USA or Puerto Rico ONLY

When you ship the product

- Carefully pack your unit, preferably in the original carton
- Attach a letter, detailing the symptom, to the outside of the carton

Symptom

- Send the unit to an authorized servicenter, prepaid and adequately insured
- Do not send your unit to the Panasonic Consumer Electronics Company listed below or to executive or regional sales offices. These locations do not repair consumer products

- This cordless telephone is designed for use in the United States of America. Sale or use of this product in other countries may violate local laws.
- Ce telephone sans fil est conçu pour être utilisé aux États-Unis d'Amérique. La vente ou l'emploi de cet appareil dans certains autres pays peut constituer une infraction à la législation locale.
- Este teléfono sin cordón fue elaborado para uso en los Estados Unidos de América. La venta o el empleo de este producto en ciertos países puede constituir violación de la legislación local.
- このコードレス電話機は、日本国外での使用を目的として設計されており、日本国内での使用は法律違反となります。従って、当社では日本国内においては原則として修理などのサービスは致しかねます。

**Panasonic Consumer Electronics Company,
Division of Matsushita Electric Corporation of America**
One Panasonic Way, Secaucus, New Jersey 07094

**Panasonic Sales Company,
Division of Matsushita Electric of Puerto Rico, Inc.**
Ave 65 de Infantería, Km 9 5, San Gabriel Industrial Park
Carolina, Puerto Rico 00985